

BEDFORD

STONE WORKING MACHINERY



Bedford Foundry &
Machine Company
INCORPORATED
Bedford, Indiana

BEDFORD STONE WORKING MACHINERY

Planers, Gang Saws, Diamond
Saws, Electric Cranes, Channelers,
Power Hoist, Steel Derricks, Steel
Buildings, Steel Tramways,
Grout and Slush Boxes



ALL KINDS OF QUARRY AND
MILL EQUIPMENT

BEDFORD FOUNDRY & MACHINE CO.

Incorporated

MAIN OFFICE *and* WORKS, BEDFORD, INDIANA



View of plant of Bedford Foundry & Machine Co., Bedford, Ind. 1924

Foreword



OUR plant being located in the heart of the Indiana Limestone District and with our many years of practical experience together with ideas derived from the stone men who operate stone working machinery we can confidently offer the machines herein illustrated and described as the best yet produced. It is impossible within the limits of this catalogue to describe all the stone working machinery we build and therefore solicit correspondence from anyone not finding within these pages the machines that are exactly suited for their needs. The few succeeding pages together with the following illustrations show the different types and details of the improved machines we have recently originated and designed.

The heads of industries, whose problems call for rapid and efficient handling of volume will be interested in the showing of BEDFORD STONE WORKING MACHINERY as illustrated and described in this catalog. the strongest endorsement of the products of the Bedford Foundry & Machine Company is their performances in the telling test of meeting satisfactorily the demands of everyday work.

The true mechanical principles of design, the high test materials employed and the accurate machining and assembling of this machinery has been the guiding policy that has resulted in the rapid growth of our business from the modest foundry of 1902 to the completely equipped, modern plant of today. With present facilities and personnel we are prepared to handle structural steel work, including steel buildings, steel runways and steel tanks—in fact, anything in the structural steel line. We can also take care of all kinds of gray iron castings up to twelve tons and our machinery department is equipped for handling all kinds of machine work. Nothing too large or too small.

We have at all times a capable engineering staff who will be pleased to co-operate with you or give you the benefit of their experience in designing new buildings or intricate machinery.

Our mechanical facilities and staff of designers and construction engineers place us in a particularly advantageous position to make it worth your while to have us figure with you on your requirements

Bedford Improved Worm Driven Planer



WHILE the Bedford Improved Stone Planers are built in several types to meet various requirements, the following description of material and method employed in the construction of the component parts and equipment will apply generally and serve as a guidance in the selection of machines of the type to meet your requirements.

Gearing All driving gears are turned and finished with the teeth cut from the solid, and are as silent running as metal gears can be made. The rack is made of high grade cast iron, securely bolted to the platen, and teeth cut from the solid metal. The worm is of forged steel, $6\frac{3}{4}$ inches in diameter, 12 inches long, accurately turned, and runs constantly in oil. Worm shaft is provided with ball bearing take-up to compensate for wear. This is located in a cast iron box, which is cast in the pulley bracket and runs constantly in oil. Take-up is easily accessible and does not necessitate running platen off the shear to take up the wear.

Bed The bed is extra long and deep, with heavy sides and thoroughly braced with wide cored ribs, placed at short intervals; has broad V's with side lock and automatic oilers.

Platen The platen is very heavy, of the double deck pattern, and strongly ribbed to secure ample stiffness. It is provided with numerous stake holds, and ways are accurately planed and fitted to bed.

Posts The posts are very heavy, of strong box pattern, with broad planed faces. The top is accurately planed for tie or top plate and bases are planed and secured to bed with turned bolts.

Cross Rail Heavy pattern of great depth and of proper form to resist the strains brought upon it when taking a heavy cut. It is accurately planed to meet face of post and is secured to same by dovetailed connection. Openside planers have an extra heavy brace extending from the outer end of cross rail to back of post, making cross rail positively rigid. Nuts are fitted to planed surfaces on back of cross rail and brace. Cross rails are arranged to raise and lower by power, and all sizes, except the openside are fitted with two tool heads.

Tool Heads One tool head is also furnished on each post. All side stocks are arranged to raise and lower by power. The tool heads are very strong, provided with double tool bars and steel set screws for holding as many tools as the machine is capable of driving. All sliding parts are accurately fitted with steel gibs to take up the wear and also to lock when necessary. Feed screws driving tool stocks are of steel running in bronze nuts. Hand wheels have finished rims.

Driving Mechanism Pulley brackets are made extra heavy and strong and well braced to avoid vibration. Pulleys are all large in diameter and loose pulleys are bushed with bronze. The reverse arrangement is so arranged that belts can be shifted from either side of the planer, or when set will reverse automatically. Trip dogs are provided with latches which can be lifted with the finger, permitting the platen to run out as far as desired for loading, etc. One overhead countershaft with pulleys and hangers is furnished with each machine.

Cross and Vertical Tool Attachment Through an arrangement of miter gears the feed screws on cross rail and side stock are arranged to drive by power for cross and vertical tooling. This is very simple and is controlled by two small handles placed convenient for the operator. This attachment is only furnished when so stated in this contract.

Circular Planing Attachment This attachment consists of a movable platen, which is mounted upon the regular planer table in such a manner that it is free to swing in either direction, turning upon a pivot pin at its center. This is operated by a guide bar which is attached to the planer bed by brackets, and may be placed either parallel to the motion of the machine or at any angle to this motion, allowing either a straight cut to be taken or a curve of any radius can be cut. This arrangement is only furnished when so stated in this contract.

General The general design and construction of this machine is of the latest improved type, the best and most suitable material being employed. The castings used are of high grade iron, all neatly finished. The entire machine is neatly and serviceably painted. A thorough substantial and workmanlike machine, in strict accordance with our specifications, is guaranteed.

Drawings are furnished the purchaser for foundation and erection, when requested, free of charge.

We manufacture either the large double machine or the openside machine. The large machine has four tool heads with solid cross rail and split platen. The double platen machine has quite an advantage over the single platen inasmuch as the two sides can be run separately if necessary and operators are entirely independent of each other.

In some case the openside machine has the advantage of the large machine, from the fact that same do not limit the size of stone to be planed. For instance, a wide stone that is to be planed on two sides can be placed on this machine with the rough side projecting over the edge of the platen, while the two heads will cover the finished part of the work.

SIZES OF OUR STANDARD PLANERS

Double

6 feet 4 inches wide, 4 feet 0 inches high, 12 feet 0 inches long
6 feet 4 inches wide, 4 feet 0 inches high, 14 feet 0 inches long
6 feet 4 inches wide, 4 feet 0 inches high, 16 feet 0 inches long
8 feet 6 inches wide, 4 feet 0 inches high, 12 feet 0 inches long
8 feet 6 inches wide, 4 feet 0 inches high, 14 feet 0 inches long
8 feet 6 inches wide, 4 feet 0 inches high, 16 feet 0 inches long

Single

3 feet 0 inches wide, 3 feet 0 inches high, 12 feet 0 inches long
3 feet 0 inches wide, 3 feet 0 inches high, 14 feet 0 inches long
3 feet 0 inches wide, 3 feet 0 inches high, 16 feet 0 inches long
3 feet 6 inches wide, 3 feet 6 inches high, 12 feet 0 inches long
3 feet 6 inches wide, 3 feet 6 inches high, 14 feet 0 inches long
3 feet 6 inches wide, 3 feet 6 inches high, 16 feet 0 inches long
4 feet 0 inches wide, 4 feet 0 inches high, 12 feet 0 inches long
4 feet 0 inches wide, 4 feet 0 inches high, 14 feet 0 inches long
4 feet 0 inches wide, 4 feet 0 inches high, 16 feet 0 inches long

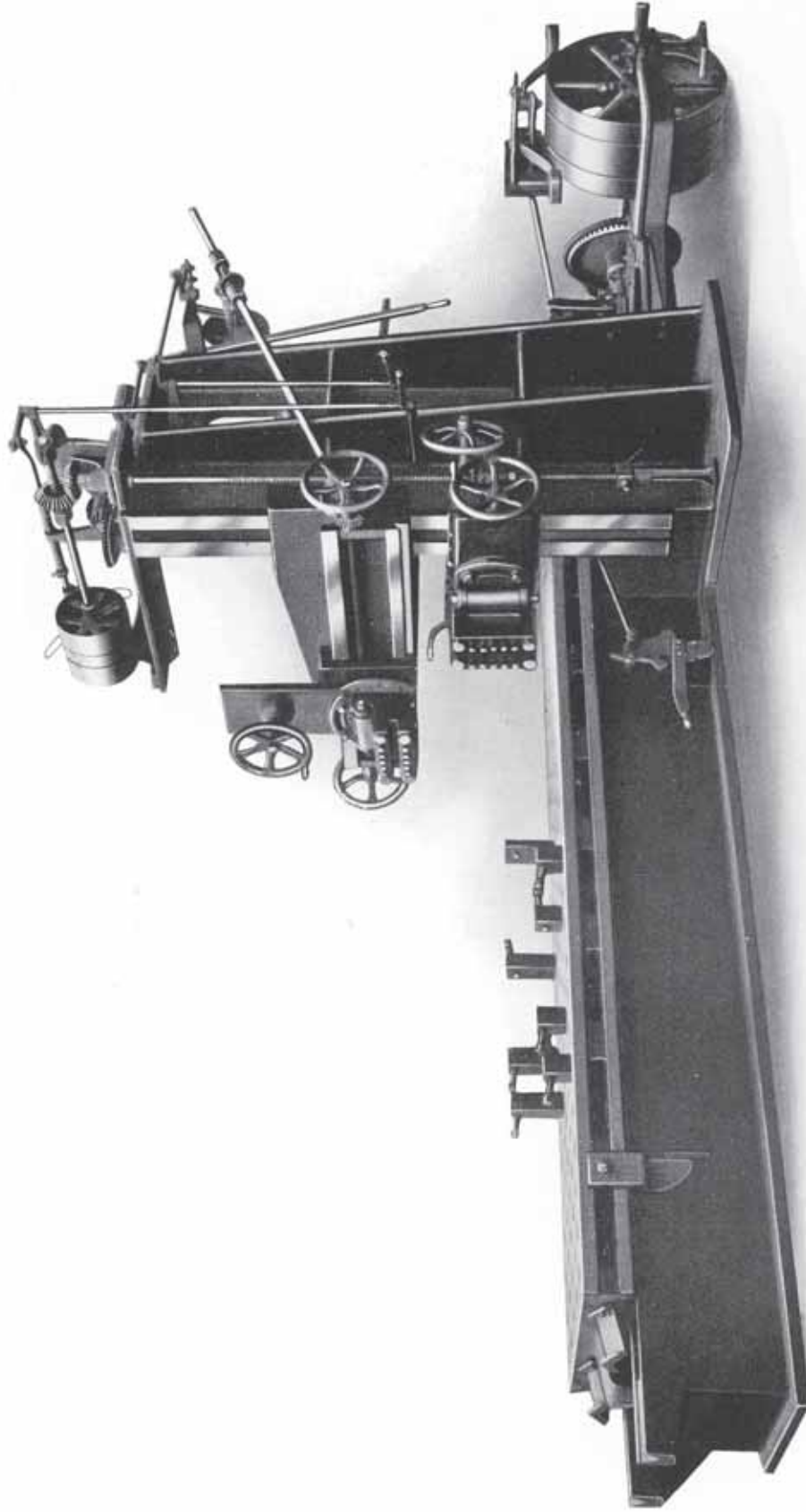

Standard 42" x 42" x 12' 0" Openside Worm-driven Planer. Latest Pattern.

Openside Planers ARRANGED TO BE
COUPLED TOGETHER

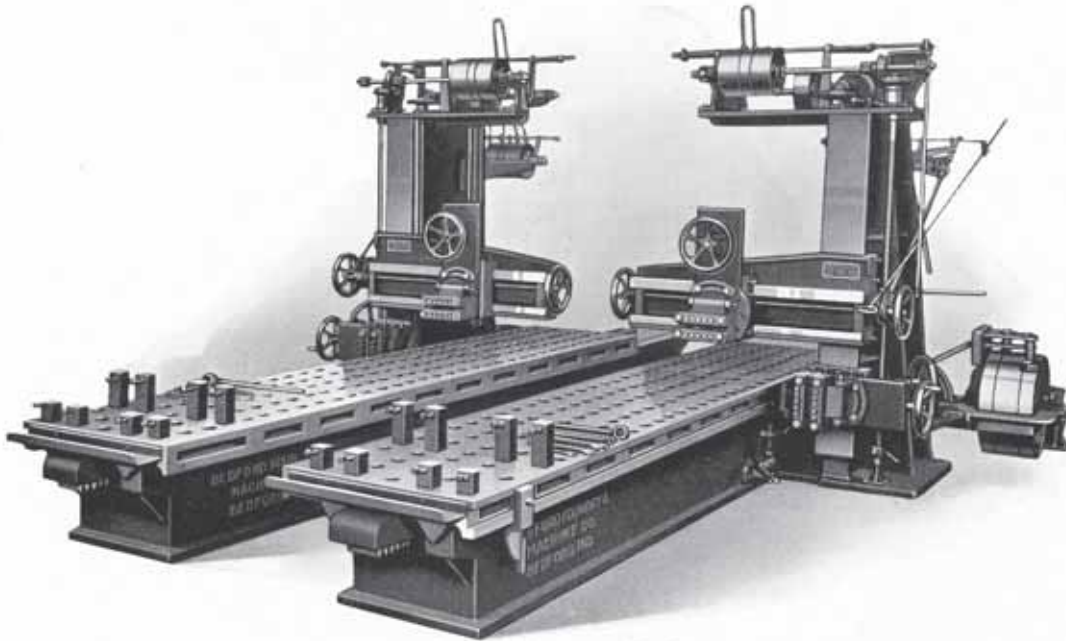

Set 1' 6" between Beds

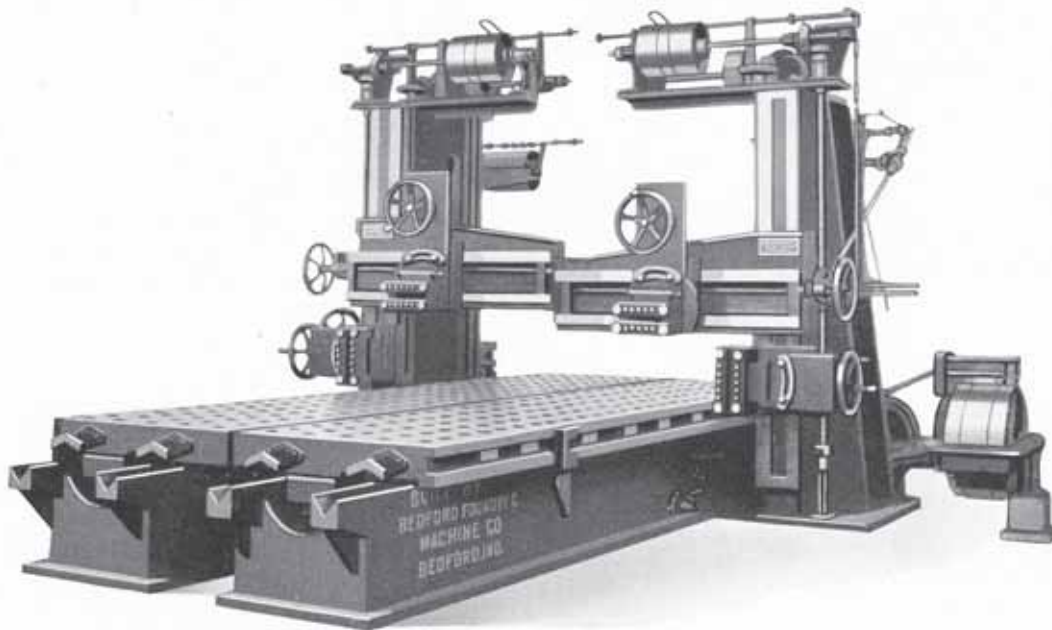

Set 1" Between Beds

The above illustrations show Bedford Openside Planers, which at small expense can be arranged for coupling them together, thus making one large wide machine. With this arrangement this machine can be converted into one large machine, or two separate machines in a few minutes, which makes them a valuable combination for both large and small work.

Front View of Six-Foot
Double Bed Planer,
Spiral Driven

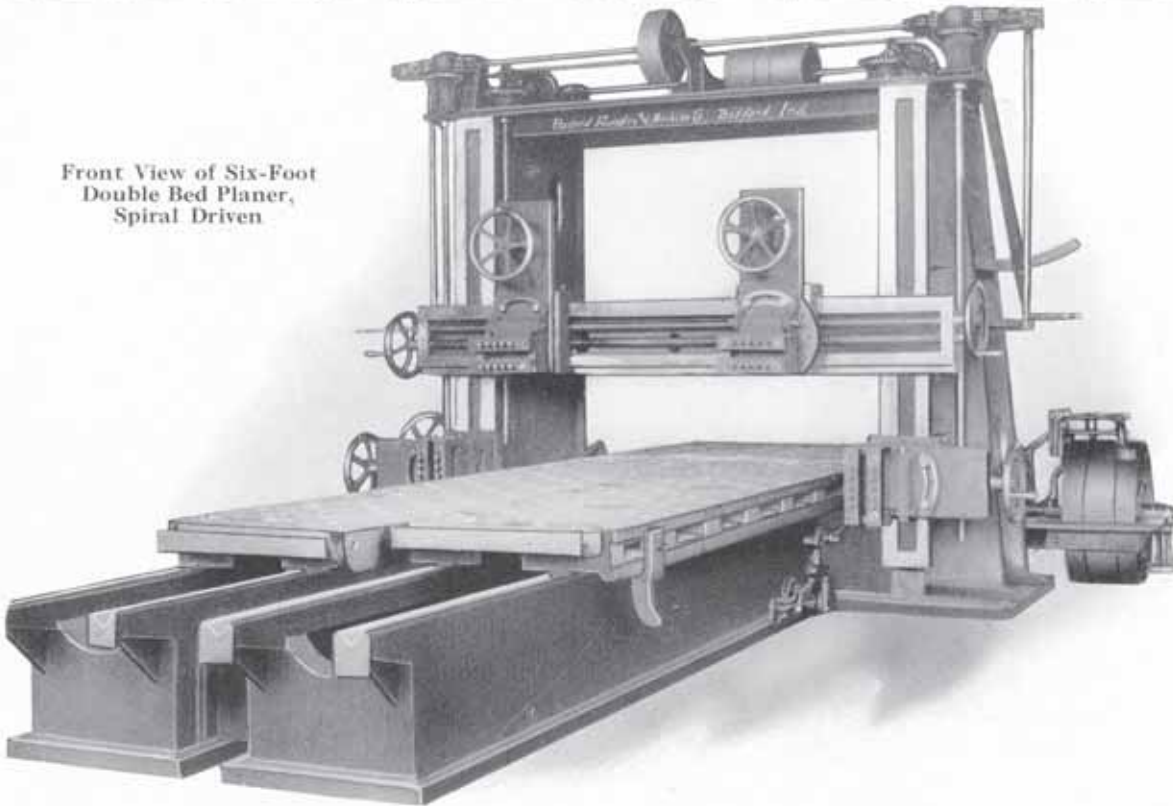

Rear View of Six-Foot
Double Bed Planer
Spiral Driven

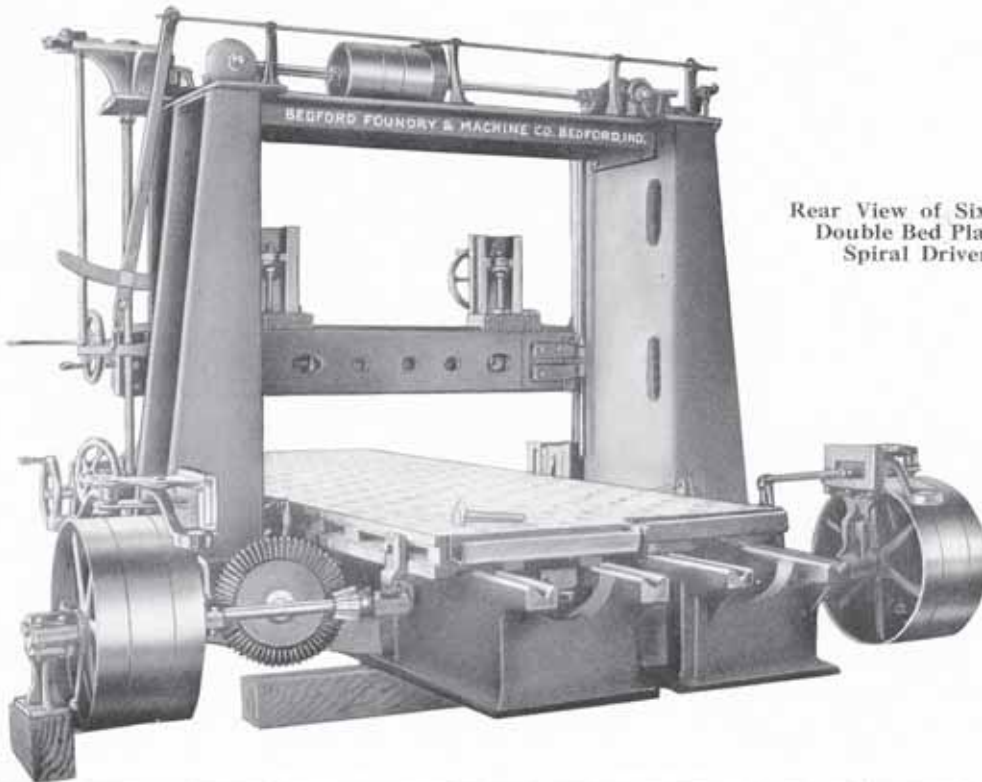

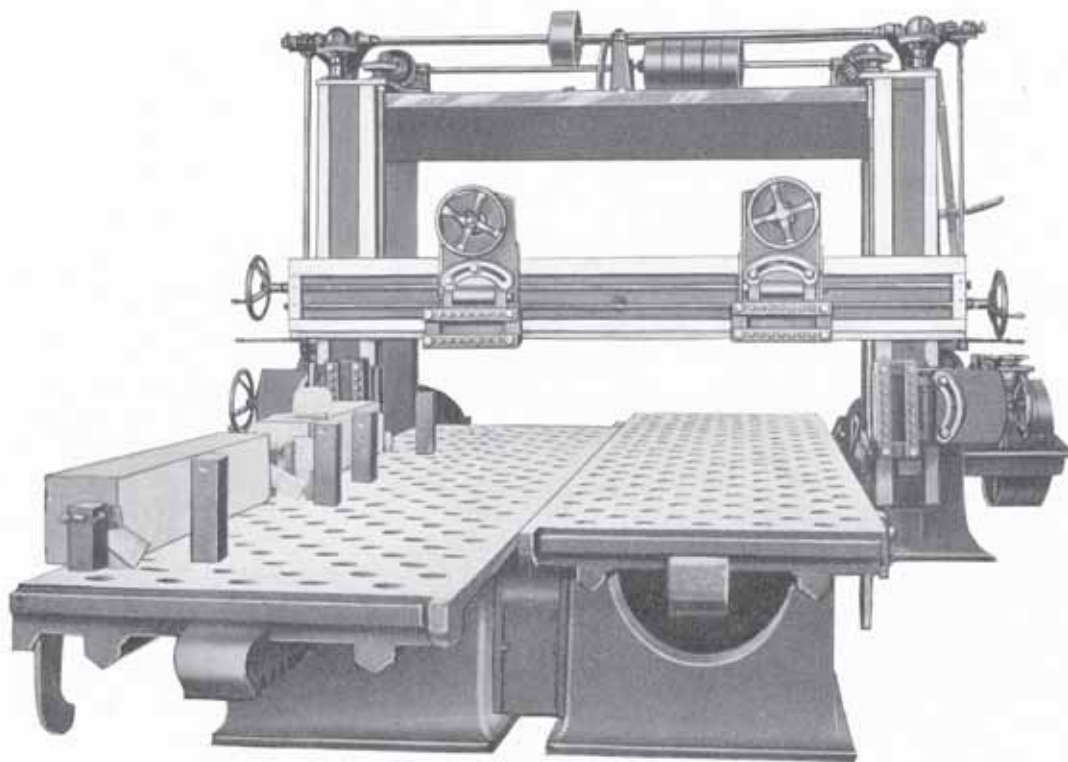

Front View of Eight-Foot Double Bed Planer, Spiral Driven

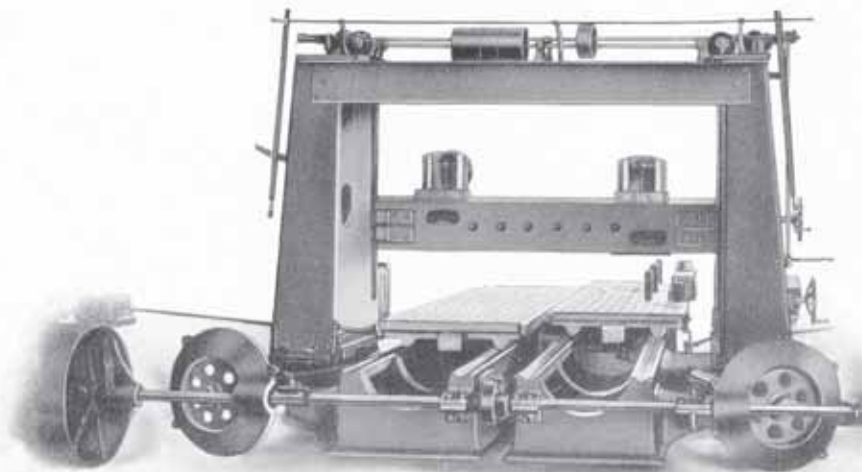

Rear View of Eight-Foot Double Bed Planer, Spiral Driven

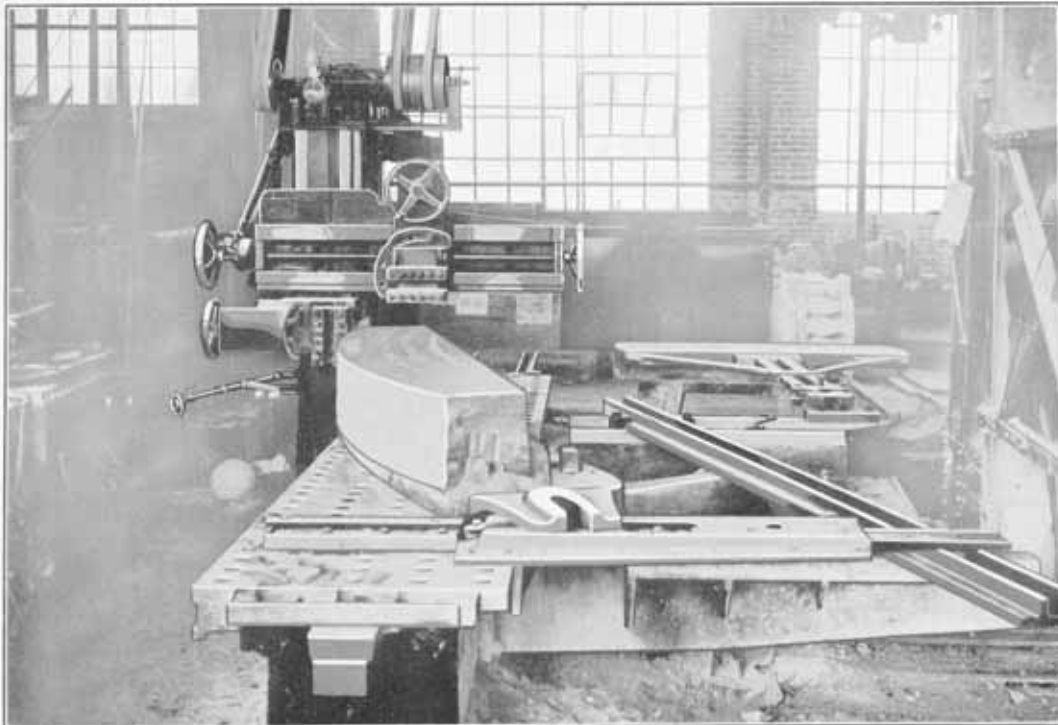

Front View Right Hand Openside Planer with Circular Attachment, Large Bed

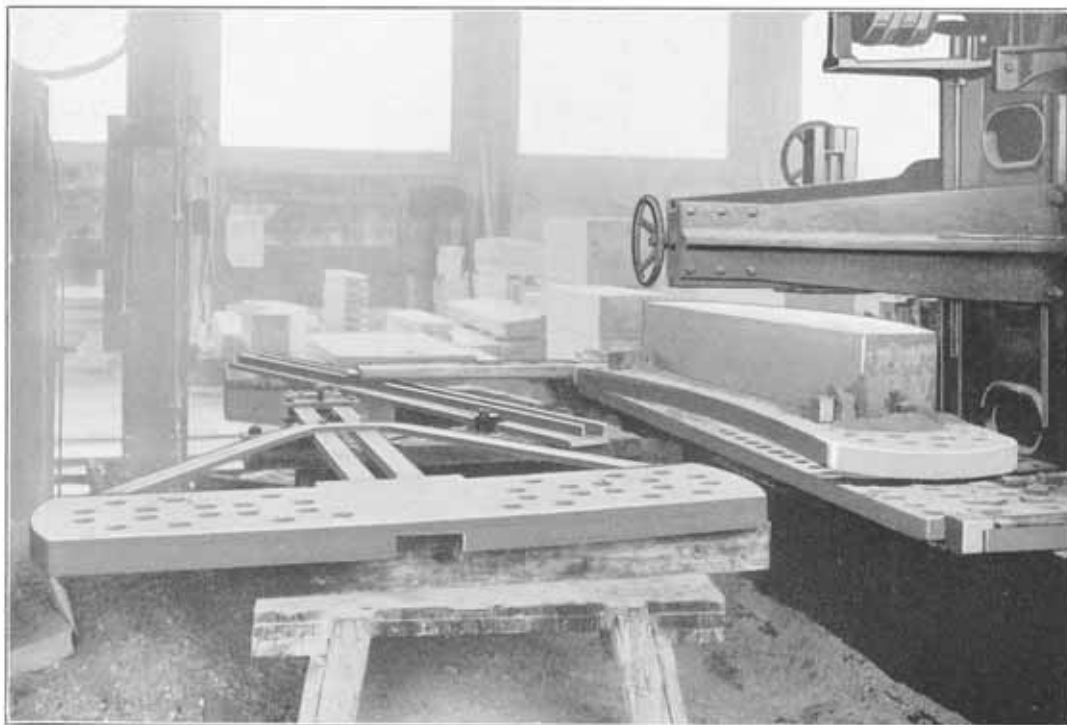

Rear View Right Hand Openside Planer with Circular Attachment, Large Bed

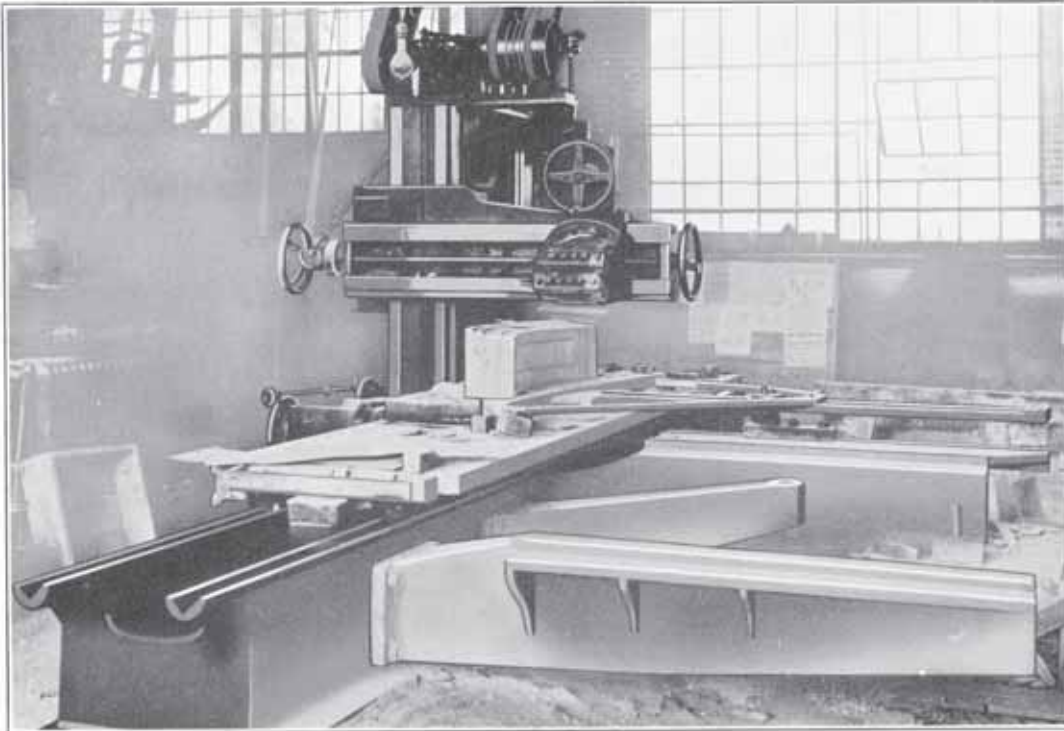

Front View Right Hand Openside Planer with Circular Attachment, Small Bed



Rear View Right Hand Openside Planer with Circular Attachment, Small Bed

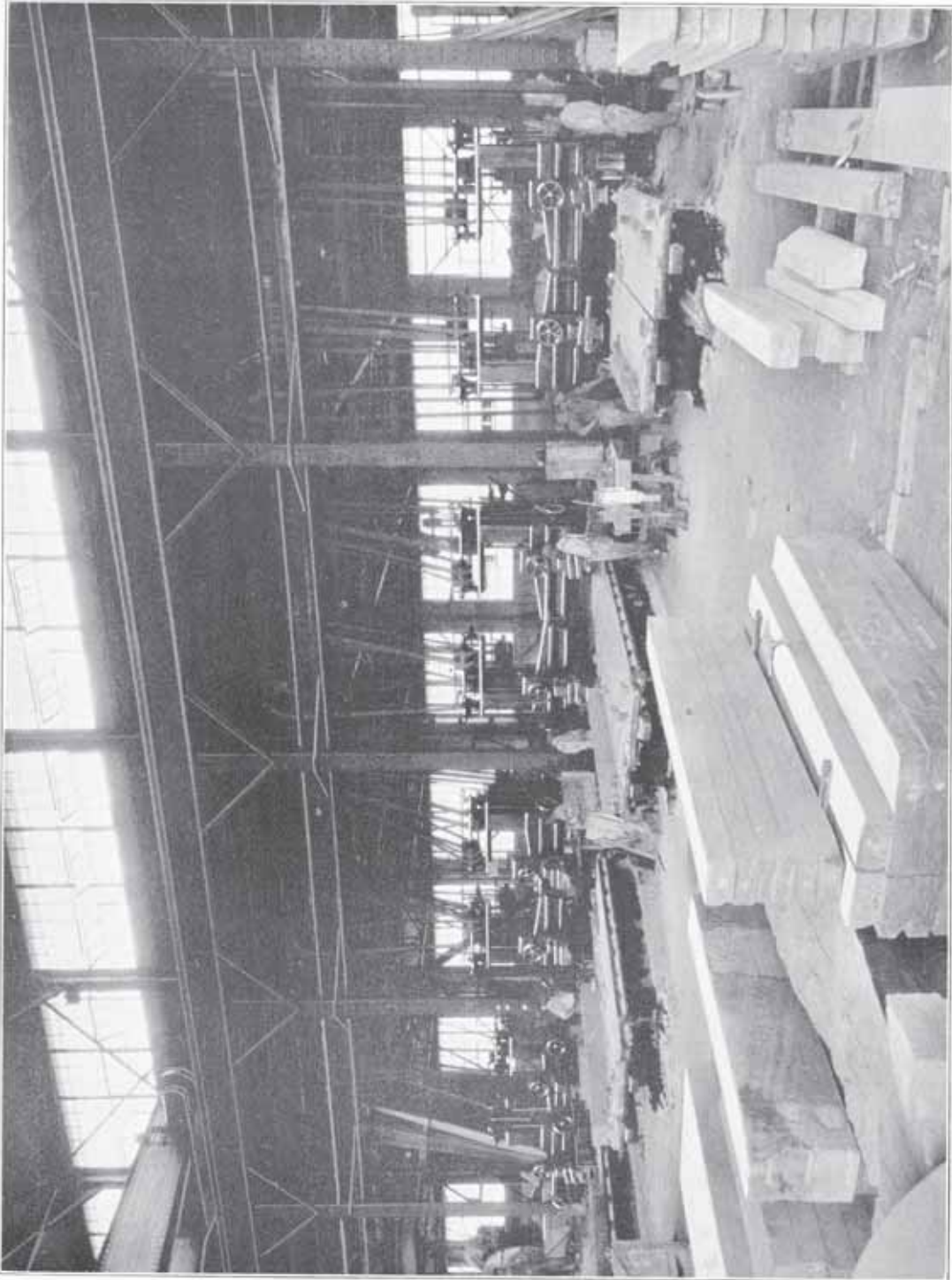

Consolidated Stone Co., Bedford, Indiana, showing 12 Bedford Openside Planers of the 18 now in operation in New Mill

Bedford Improved Stone Milling Machine



IN the following page we illustrate our new style STONE MILLING MACHINE and what we claim to be the most worthy tool in a modern stone plant of today. The following description of material and methods employed in the construction of the component parts and equipment are general and serve as a guidance in explaining the type of this machine. The object in designing a machine of this type is for the purpose of doing away with a considerable lot of hand work, which heretofore has had to be done by stone cutters. Such work as can be done with this machine is cutting all types of molds, return molds, dentals, lintels, panels, also fret work and a considerable lot of other work. In taking the above work into consideration it has been demonstrated that the machine will do as much work as five men. The machine is capable of taking a block of stone 10' 0" long by 36" wide by 24" high. It also has a variation of speeds for the feed on the cross rail as well as the bed, which makes it convenient for either using larger cutters or small cutters. The bed is also arranged for a quick return of the bed, which is essential for spotting work, and any speed desired of the platen, cross rail or tool head can be instantly changed to suit conditions.

Tool Head The tool head on the cross rail is arranged to raise and lower with a worm, with an adjustment of 8" without raising the cross rail, and is provided with an extra large spindle driven through a worm gear, which is run by a spline shaft directly connected to pulley from motor or countershaft. The belt driving this pulley is arranged with a belt tightener which automatically takes up the slack of the belt when the cross rail is raised and lowered. And also built with a gear box arranged with three speeds on the spindle.

Gearing All driving gears are turned and finished, and teeth cut from the solid, and are as silent running as metal gears can be made.

Bed The bed is extra long and deep, thoroughly braced with wide ribs placed at short intervals having broad V's of extra width, and the distance between track V's is such that there is no possibility of the table tilting. Each V is fitted with an automatic roller oiling device which assures thorough lubrication.

Platen The platen is extra heavy, of unusual thickness, and braced at short interval with heavy ribs to guard against any possibility of springing. Platen is accurately fitted to the bed and provided with holes to receive stakes for securing the work,

Uprights The uprights are very heavy and strong, box pattern with broad plain faces the top accurately planed for the top plate, and the base is planed and secured to the bed with turn bolts.

Cross Rail The cross rail is heavy pattern of great depth and of the proper form to resist the strain brought upon it when taking a heavy cut. It is accurately planed to meet the face of post and is secured to same by a dove-tail connection. Cross rail is also arranged to raise and lower by power.

Driving Mechanism Driving mechanism is composed of a pulley bracket shifting arrangement, together with a variable speed transmission, extra heavy and strong and well braced to avoid vibration. Pulleys are large in diameter and the loose pulleys are bushed with bronze. One overhead countershaft with pulleys and hangers are furnished with each machine.

General General design and construction of this machine is of the latest improved type and the best and most suitable material being employed. The castings are all high grade iron, all neatly finished. The entire machine is neatly and serviceably painted. A thoroughly substantial and workmanlike machine in strict accordance with our specifications is guaranteed. Drawings are furnished the purchaser for foundation and erection, when requested, free of charge.

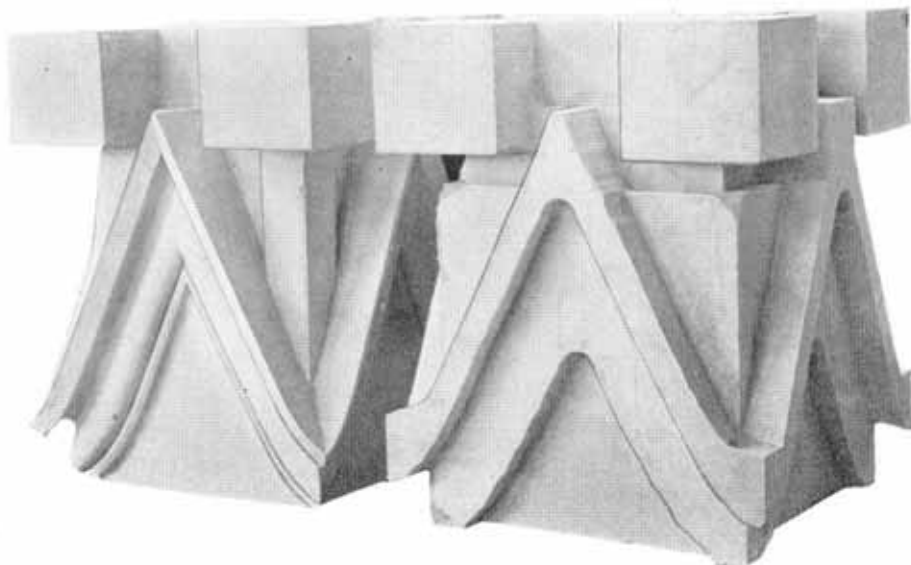
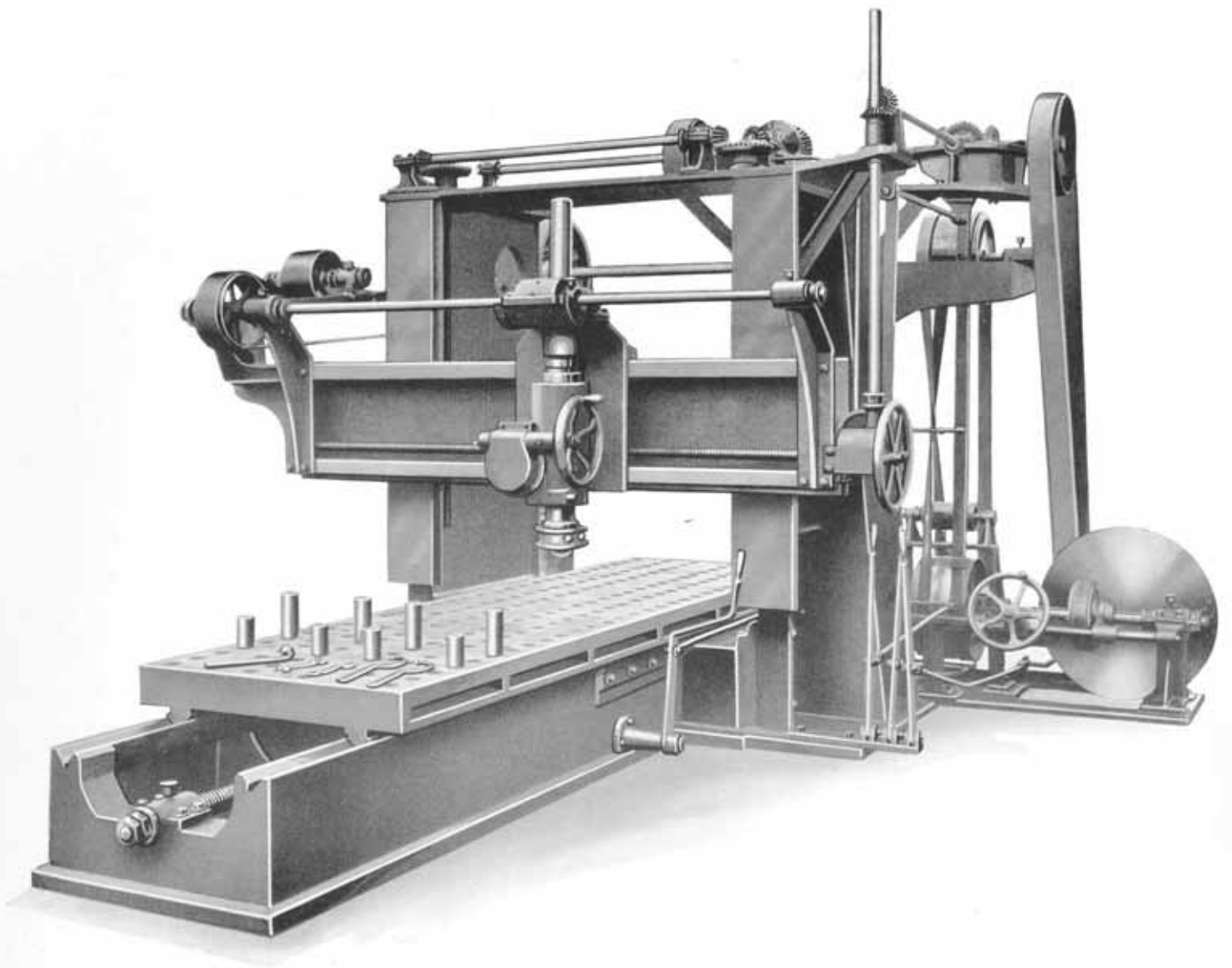

Base of Finial with Rough for Carved Crockets

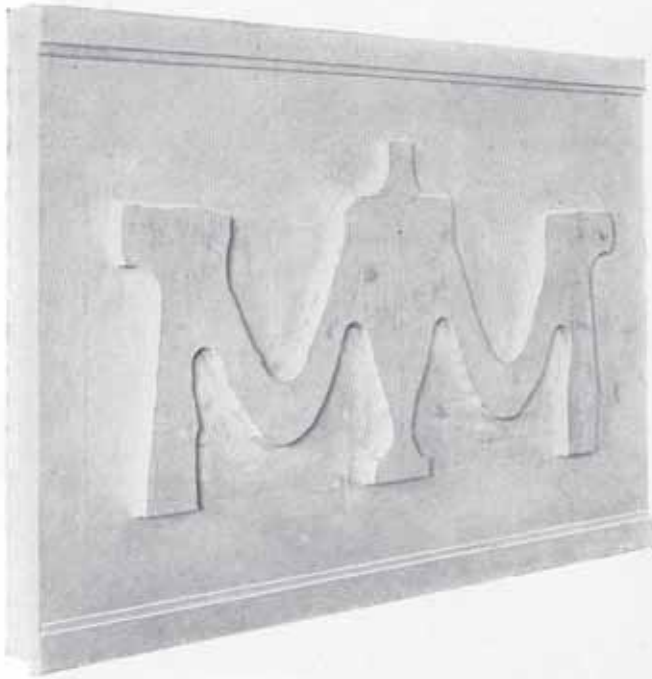

Carved Panel Roughed Over by Machine

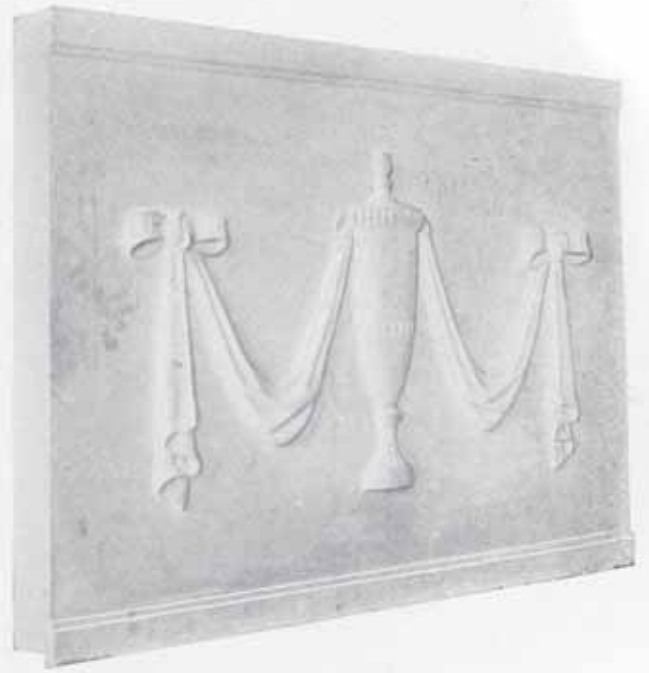

Finished Panel

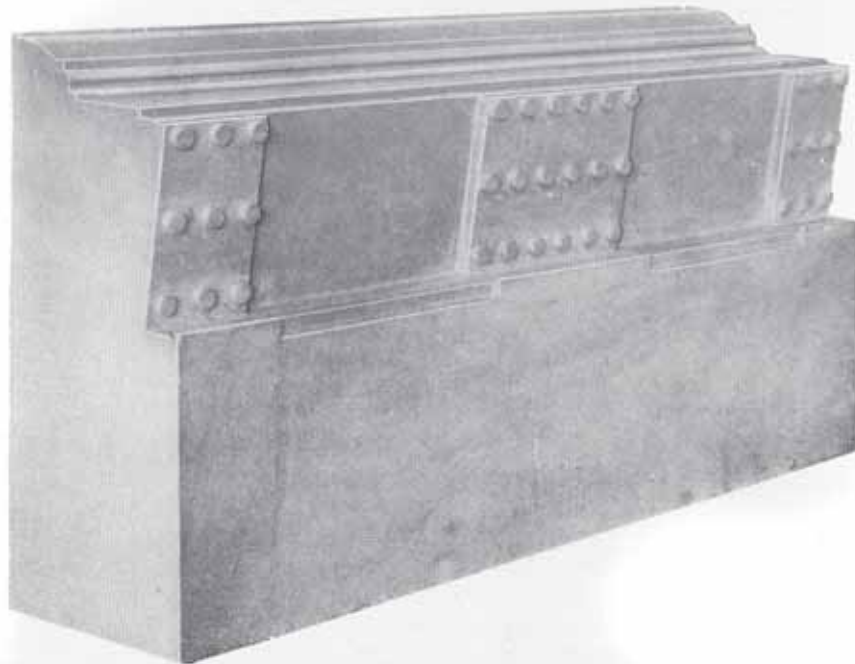

Doric Cornice with Mutule Attached

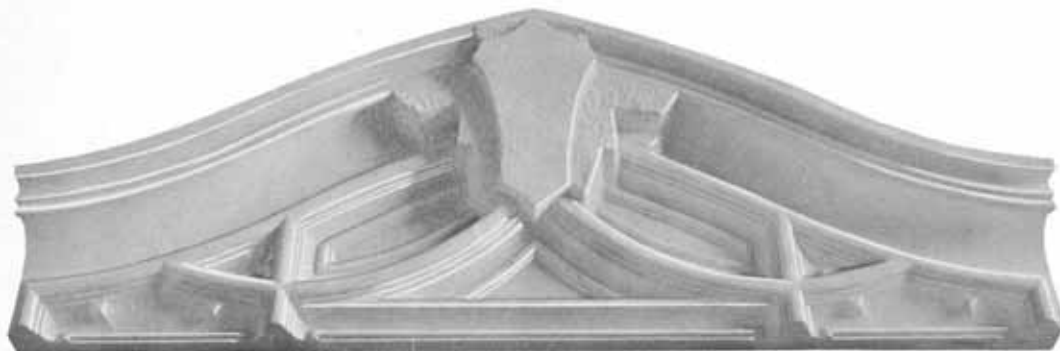

Portion of a Gothic Panel

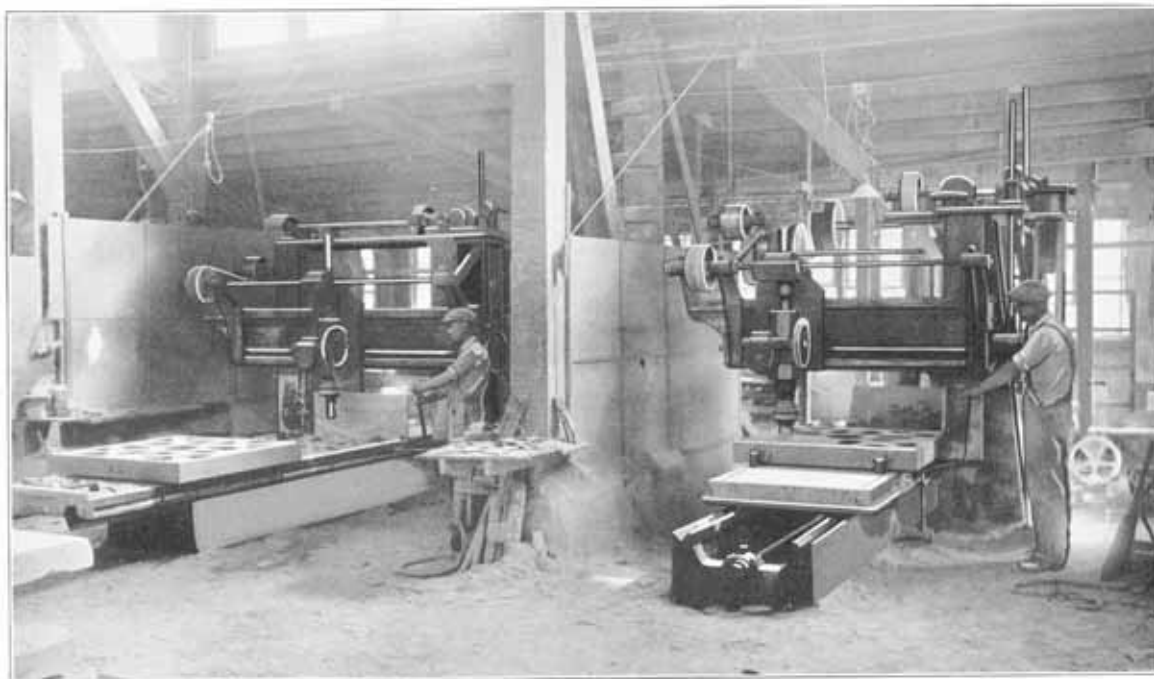

Furst Kerber Cut Stone Company, Bedford, Indiana, showing Openside
as well as Double Post Milling Machine

Bedford's Improved Diamond Saw



As a result of many years experience in the manufacture of Stone Working Machinery, we are now in position to furnish one of the best DIAMOND SAWS in the market, and to bear out this statement we are guaranteeing our machine to give absolute satisfaction in every respect.

Saw Frame is composed of two cast iron columns which form the uprights, with heavy base of step to bolt to foundation, properly braced so as to be very rigid. Upon these uprights is mounted two I beams forming the track. The top of these beams are planed forming proper alignment for the carriage. Beams are accurately fitted to shoes which fit around the upright columns, thus permitting the saw to be raised and lowered. The upright columns and shoes are turned true.

Saw Carriage is all made in one piece and is mounted on four truck wheels double flange, which are accurately turned to run on these I beams parallel. The carriage will be driven with a sufficient size motor, depending upon the size of blade, of the General Electric Co. type, which drives the saw mandrel through a silent chain arranged to give the proper speed. Mandrel will be of high grade steel, ground true and fitted into ring oiling babbitt bearings. Carriage straddles the I beams or track and is driven from one end of mandrel with the saw on the other end. This absolutely balances the machine and does not have any overhang.

Feed Mechanism is driven with an ample size motor of the General Electric Co. type depending on the size of the saw mentioned and is mounted on end of saw frame driven through a silent chain to feed, which is of the worm geared type and screw running in a bronze nut. Variable speed is arranged for the saw, ranging from 4½" to 17" per minute cutting speed, pulling speed and backing out speed 14' 9" per minute. Arrangements are also made to raise and lower the saw by power at 26" per minute.

Trucks Machine is provided with double trucks, each truck mounted on six wheels and three axles. Wheels are chilled and shrunk on the axles. Axles run on roller bearings and are supplied with ratchets and levers for moving the trucks on the track, and are also provided with foot locks which lock the trucks when saw is in operation. Truck frames are made entirely of steel and top is provided with channels planed true so as to set stone square

Switchboard and Wiring Stone or slate slab will be furnished together with the necessary switches, fuses and compensator for operating the two motors. This will be furnished with all connections ready to receive your wires.

General The saw is constructed in a high grade manner throughout and the best and most suitable material is employed. All castings are of high grade iron or steel, neatly finished and all the machine is neatly and serviceably painted, small parts, motors, etc., carefully boxed and crated for shipment.

SIZES OF STANDARD MACHINES

76-inch blade to cut 12 feet long with two steel trucks
 72-inch blade to cut 12 feet long with two steel trucks
 60-inch blade to cut 12 feet long with two steel trucks
 48-inch blade to cut 12 feet long with two steel trucks
 36-inch blade to cut 12 feet long with two steel trucks
 36-inch blade to cut 10 feet long with two steel trucks

Saw can also be made with stationary iron legs, belt driven, and hand raising and lowering.

Prices and Specifications Furnished on Application



Bedford Improved 48" Diamond Saw

**SPECIFICATIONS FOR ONE 24-INCH CARBORUNDUM SAW, 8 FOOT RIP,
HAND RAISING AND LOWERING**

Saw Frame Saw frame is composed of two cast iron columns which form the uprights with heavy base to bolt to the foundation, properly braced so as to be very rigid. Upon these uprights is mounted a cast iron box section frame forming the track. The top and bottom of this frame is planed forming proper alignment for the carriage. This frame is also accurately planed to rest on the cast iron shoes which fit around the upright columns, thus permitting the saw to raise and lower by hand wheel at one end of this frame. The upright columns and shoes are turned true and the frame is provided for an 8' Rip.

Carriage Carriage is made in two pieces and mounted on this frame which is accurately planed by slide gibs, planed true so as to run parallel. The carriage will be provided with a 10 H. P. motor which drives the saw mandrel through a silent chain arranged to give proper speed. Mandrel will be of high grade steel ground true and fitted into babbitt bearings. Carriage straddles this cast iron frame and is driven from one end of mandrel with saw on other end. This absolutely balances the machine and does not have any overhang.

Feed Mechanism The feed mechanism is driven with a 1 H. P. motor mounted on end of saw frame, driven by belt for the feed which is of the worm geared type with screw running in bronze nut. Variable speed is arranged for the saw ranging from approximately $2\frac{1}{4}$ " to $8\frac{1}{2}$ " per minute cutting speed and pulling to speed and backing out speed $7' 4$ " per minute, depending on size of blade. Arrangement is also made to raise and lower this saw by hand.

Blade This machine can be equipped with 18", 20" and 24" steel center carborundum coated blade, or 30", 32", 34" and 36" inserted carborundum tooth blade and 30", 36" and 38" Diamond blade, with either splint tooth or solid karat stones.

Trucks Machine is provided with a double truck, truck mounted on two axles and four wheels. Wheels are chilled and are shrunk on the axles. Axles run on roller bearings and are supplied with a ratchet and lever for moving the truck on the track and is also provided with a foot lock which locks the truck when saw is in operation. Truck frame is made entirely of steel, top provided with 4" hard pine covering bolted to truck with countersunk bolts. Truck will also be provided with a guide channel planed true so as to get stone square and the necessary rails will be furnished with the truck. Purchaser to furnish timbers under rails, which is a part of the foundation.

Switchboard and Wiring Stone or slate slab will be furnished together with necessary switches and fuses and compensator for the operation of the two motors, furnished with all connections ready to receive your wire, which you are to furnish from the switchboard to the motor.

General Saw will be constructed in a high grade manner throughout, the best and most suitable material being employed. All castings are of high grade iron or steel neatly finished and the entire machine is neatly and serviceably painted, small parts, motor, etc., carefully boxed and crated for shipment.

Prices and Specifications Furnished on Application

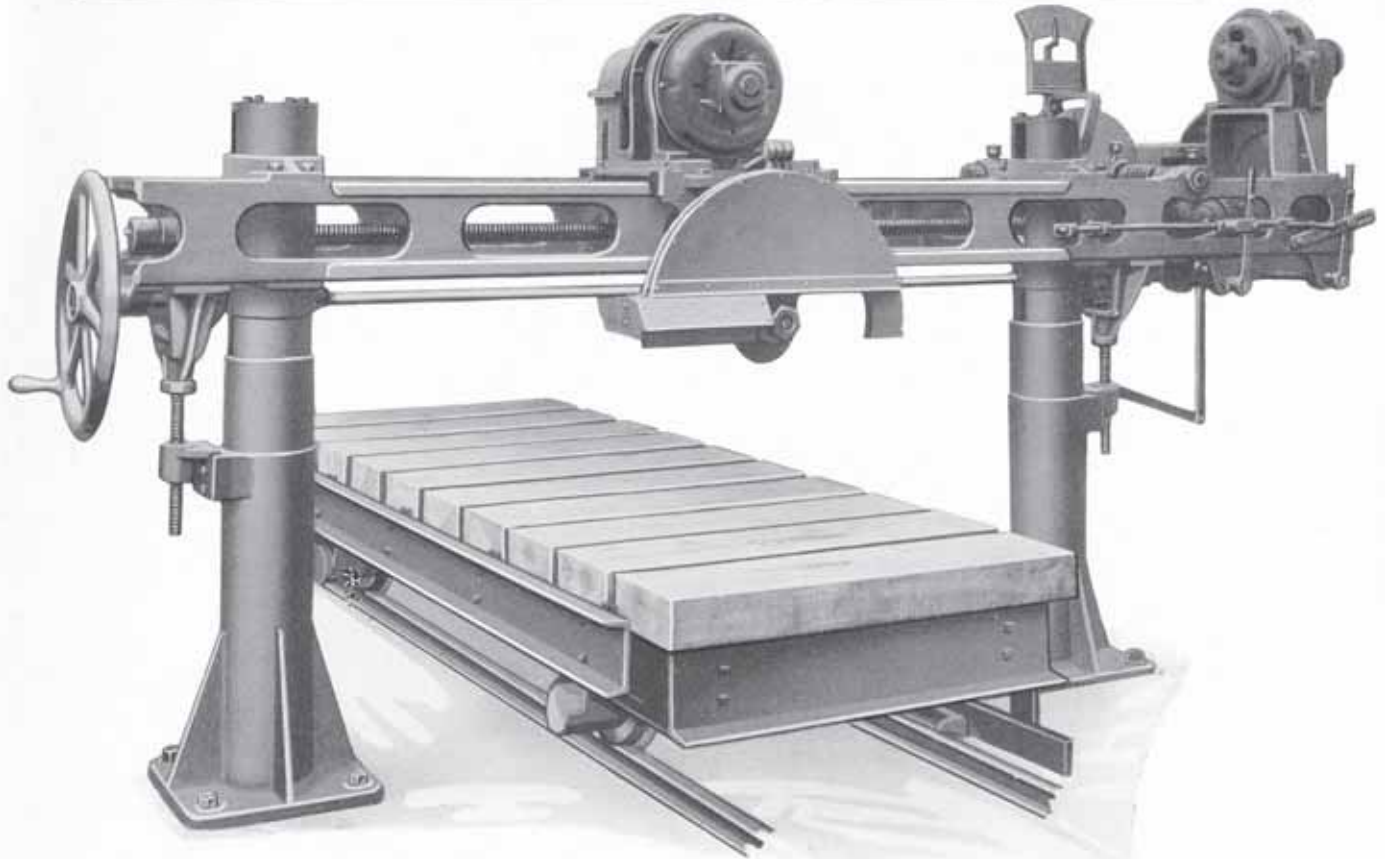

24" Carborundum Saw, 4' Rip Hand Raising and Lowering

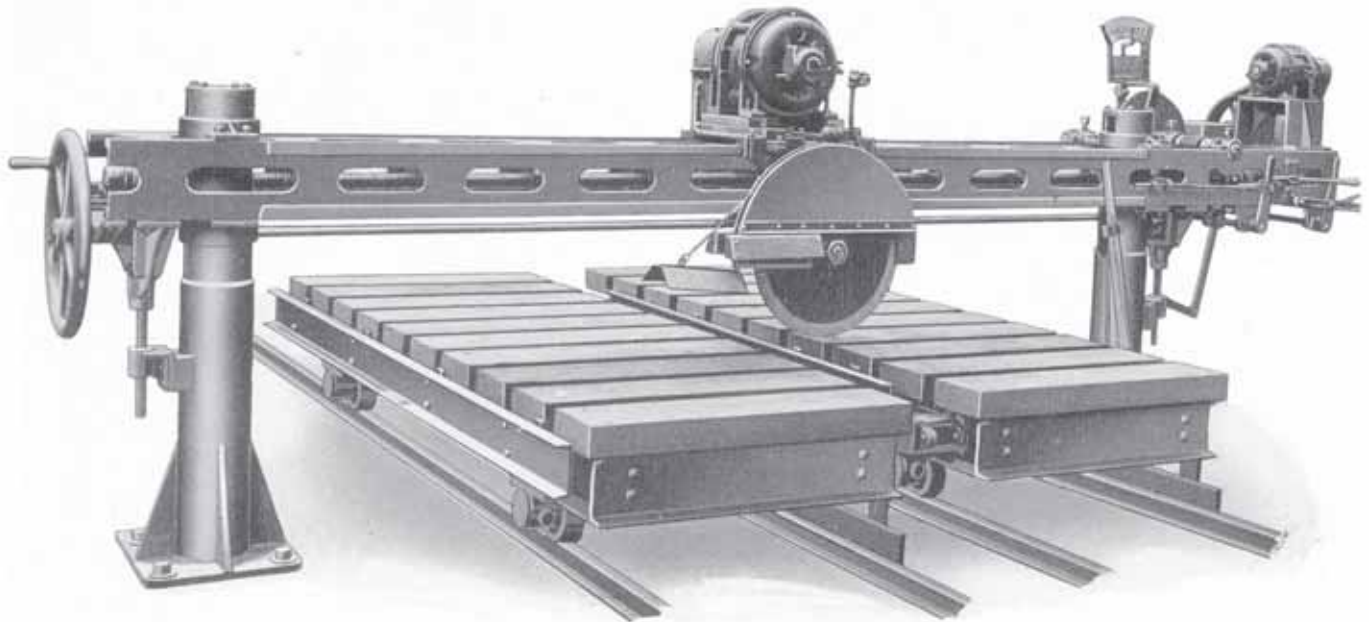

24" Carborundum Saw, 8' Rip Hand Raising and Lowering

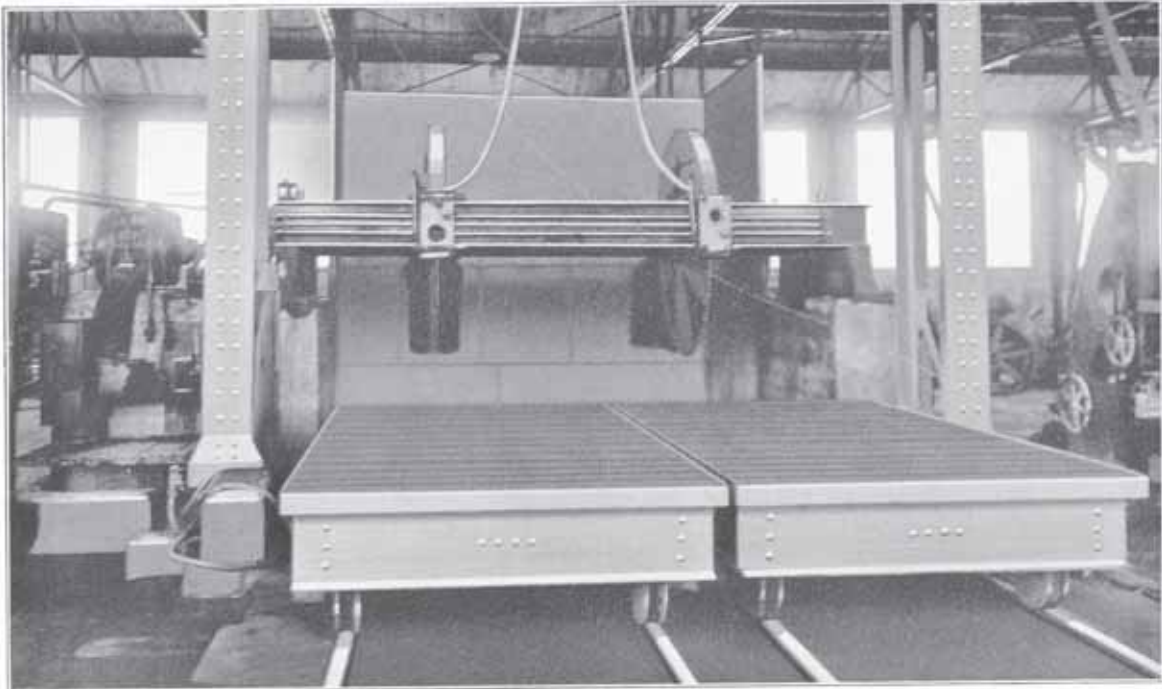

72" Double Blade Anderson Type Diamond Rip Saw, Capacity 12' long, 12' wide, 2' 6" High. Double Trucks

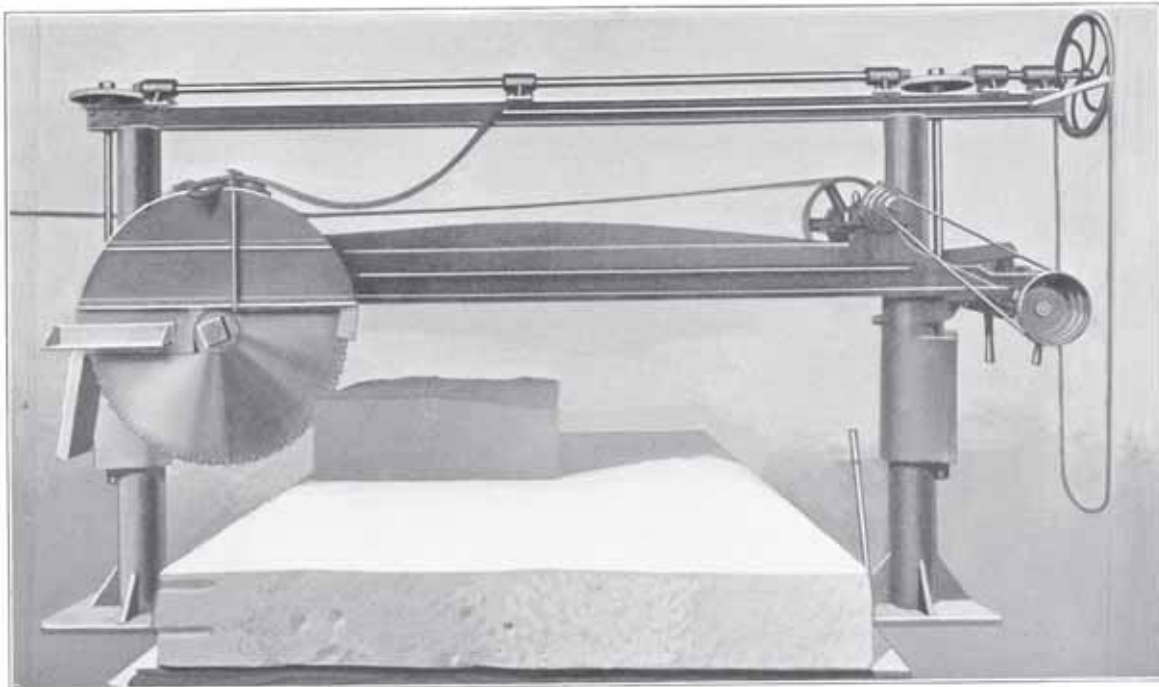

36" Diameter 8' 0" Rip, Belt Driven Diamond Saw. Single Truck

Gang Saws



THE two preceding pages together with the two following illustrations show the different types and details of our improved screw saw gang. We have recently originated and designed several improvements and among these we would mention an all iron one piece hurst frame, flat sway bars, extra heavy guides and screws. They are described in detail in the following articles.

Frame is made of structural steel and is designed to set in concrete foundation. Posts are provided with heavy base plate which is bolted to foundation with sixteen anchor bolts.

Hopper bottom in this construction is formed in the concrete foundation and there are no sills used. All lever handles, etc., are made of steel, no wood entering into the construction of this gang. The steel frame is exceedingly stiff and rigid and requires no support from the building. A lighter constructed building can thus be used. The sills are spruce. The frame is mortised or framed throughout and is held firmly together with tie rods.

The sash is constructed of 6-inch extra strong steel pipe sides. Head of the sash is channels and the corner irons are of a heavy pattern, turned to fit pipe sides. A strong, well constructed sash is thus secured.

The pitman straps are made of Bessemer steel, bearings for sway bars are at one end, in the guide saddles. These bearings are babbitted of special hard metal and ample provision is made for effective lubrication and arranged with removed caps so sway bars can be quickly removed.

All parts of this gang are so designed that any piece can be easily replaced without taking down a large part of the machine. With years of experience and intelligent designing we have perfected these gang saws to a high degree. We have eliminated all defects, strengthening the weaker parts and as a result have obtained a machine in which the strain is uniform, there being no weak points and no few parts unnecessarily heavy. These gangs as a whole are the heaviest machine of this type on the market. This being the case and the weight being properly distributed, we offer the most efficient and economical gang saw manufactured.

Complete iron work for these gangs is the same with either the structural steel or the wooden frame. Complete iron work consists of eight sets of saw dogs especially for eight saw blades, also the necessary anchor bolts, washers and the bolts for securing irons to frame work.

Truck for use with gang saws are made with either steel or hard wood frames. Truck irons in either case are the same. Truck constructed of heavy I Beams with channel ends, rigidly braced to keep frame square. Also spliced with heavy pulling stirrup at one end with rods going through truck. Truck is mounted on $3\frac{1}{2}$ " steel axles and heavy truck wheels 17" in diameter. Truck wheels have a solid bearing which afford protection from sand and water and at the same time arranged for proper lubrication. Large trucks have three axles and six truck wheels while small trucks have two axles and four wheels.

Hurst frame as illustrated is of box section very heavy and strong cast in one piece with a heavy plate, having twelve holes for $1\frac{1}{2}$ " anchor bolts. Bearings are extra long and are made for $6\frac{1}{2}$ " diameter shaft. With this arrangement it is impossible for the boxes to get out of line having no dies or other loose parts to work or give trouble. Crank shaft is of very heavy dimensions and is of the bell crank type. The thrust of this crank is evenly divided between two bearings. Fly wheel running on one end of the crank shaft is 72" in diameter, is the extra heavy design, weighing 2800 pounds. The tightener frame has its base included in the main casting. The arms are cast in one piece and support the tightener pulley with bearing on each side. These bearings are adjustable. Hurst frame being self-contained and shipped in one piece, no setting up is required.

Pitman is to be 6" x 12" yellow pine, suitable length with straps, bolts, boxes, all complete ready to put on gangs. Gangs may also be fitted with steel pitmans which are constructed of steel angles properly laced together with flat bars and fitted with straps, bolts and boxes complete, ready to put on gangs. Unless otherwise specified wood pitmans will be furnished.

Housings are of heavy pattern with planed surfaces for housing nuts and are also planed on the back where they fit to the steel frame work, so as to assure proper alignment. Housing nuts having long planed seats to hold on housings and long bearings with caps so that sway bars will revolve instead of hanger boxes revolving on sway bars. Housing and hoisting nuts are carefully fitted and securely bolted to gang frame posts.

Sway bars are of $3\frac{3}{8}$ " steel of sufficient length for width of gang.

Noddle pin. We have recently designed a much improved form of noddle pin. Two heavy castings with lugs projecting from same constructed to fit inside of heavy block. The pin is steel and made removable. Heavy U bolts hold the pin in place and strengthens the flanges of the head block through the support of the casting. The head blocks in the ordinary noddle pin are weakened by having drilled holes in these flanges to receive the bolts. The recess in the chair casting allows the dog heads to pass under same.

Hangers. We use the flat hanger strap instead of a round rod having found them much superior for strength. The straps are fitted with through bolts through a suspension box and hanger box. This gives a firm, strong construction and prevents the breaking of the hangers at the hanger box casting. The guide is very heavy and is designed to protect the screw from sand and water.

We furnish several different sand pumps including the Hawley and Frenier pumps. These pumps are automatic and will pump a mixture of sand and water or chilled shot mixture with sand and water most satisfactory. These pumps are built in two sizes, namely 12" and 16". One pump will furnish feed for one or four gangs according to the size of both gangs and pumps.

Steel distributing tank is furnished with centrifugal pump with all valves and flanges, together with countershaft, tight and loose pulleys, driving same, one split pulley for driving pump and also two ring oiling ball and socket pillow blocks to carry countershaft.

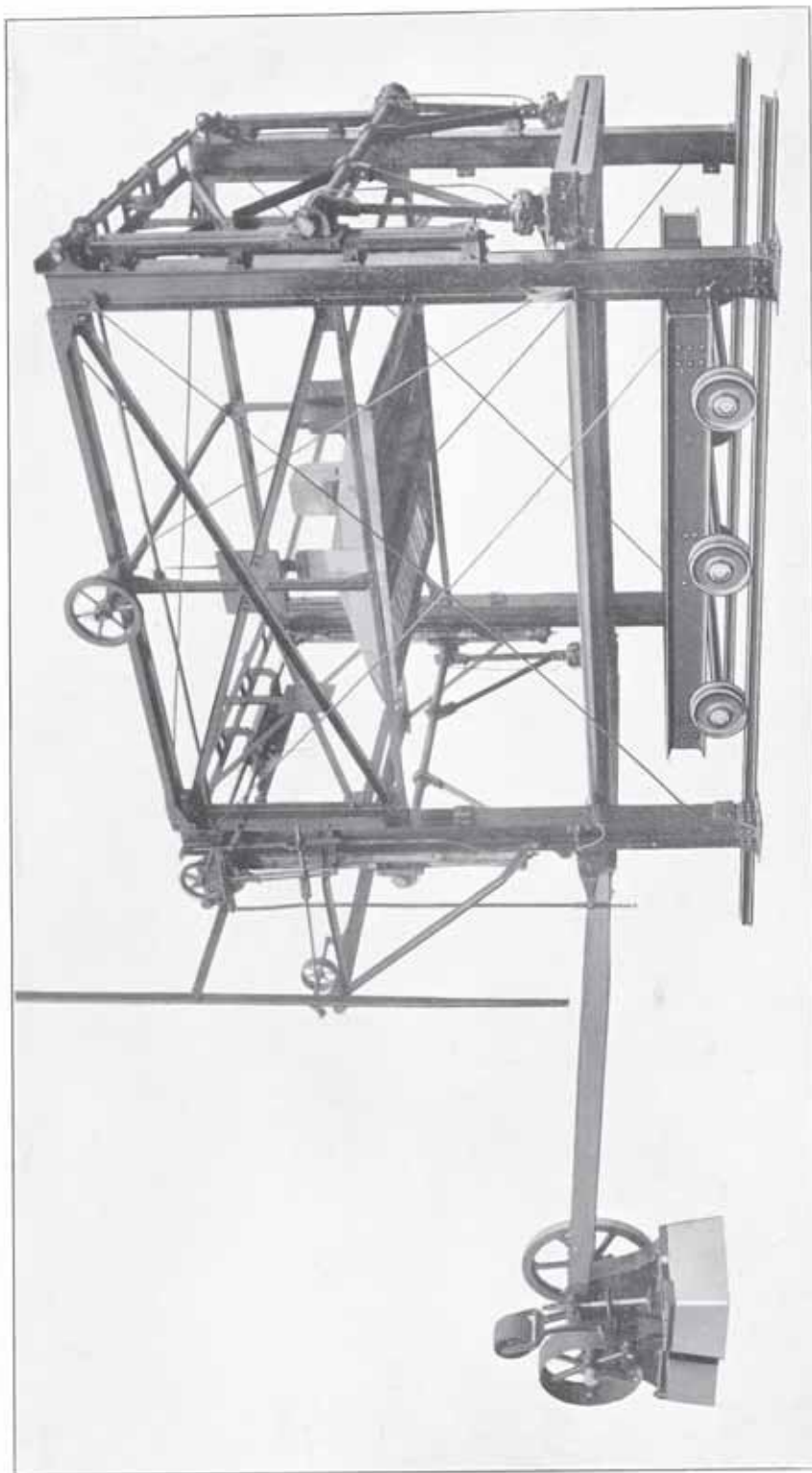

Bedford All Steel Gang Saw, 6' 0" high by 9' 0" wide by 12' 0" long, with one Piece Hurst Frame

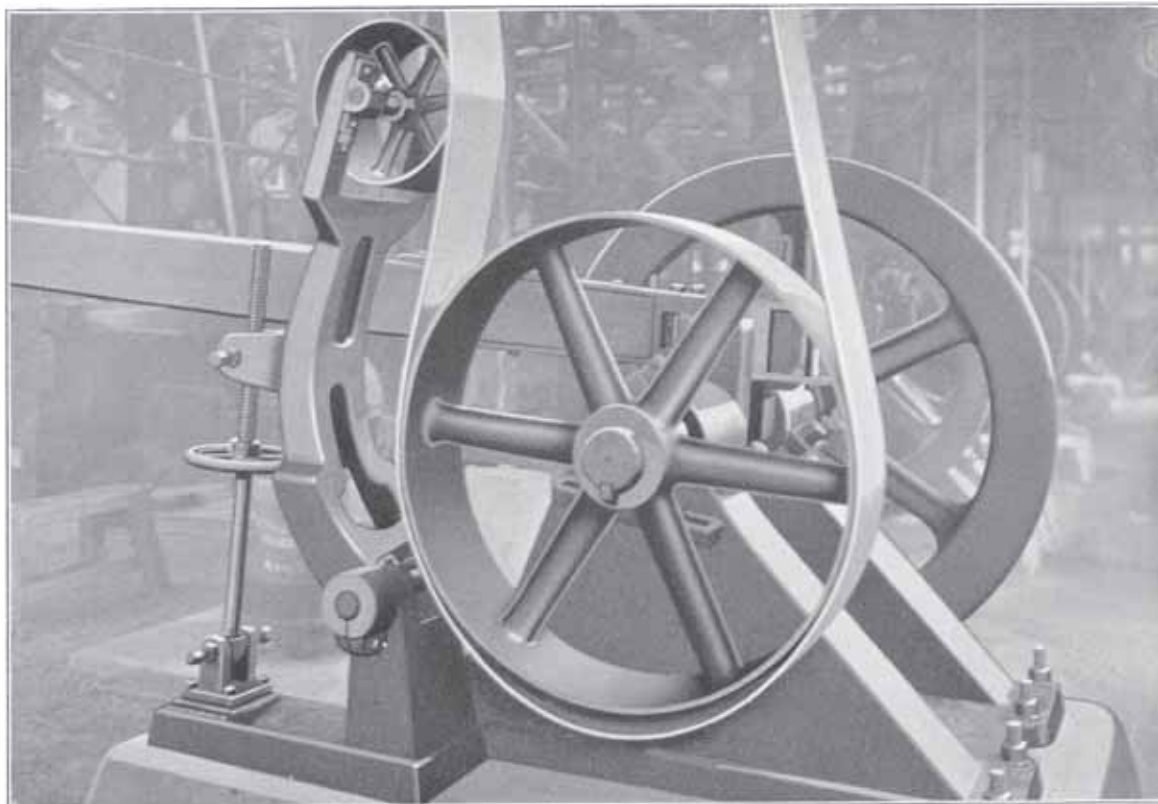

One Piece Box Type Hurst Frame, showing Adjustable Belt Tightener

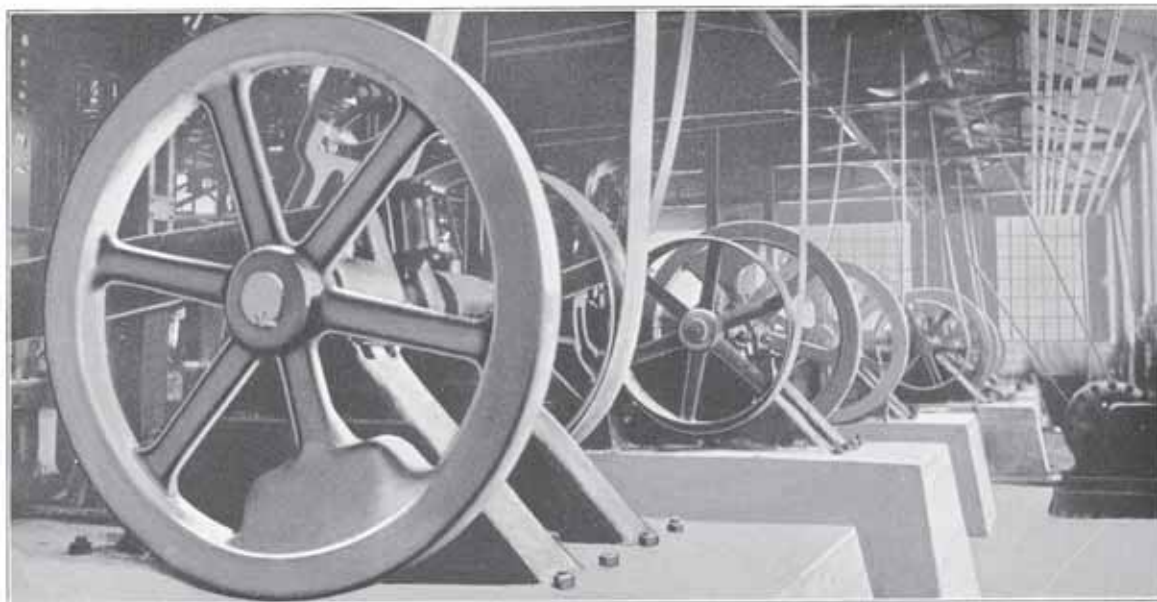

A Battery of six Hurst Frames, showing drive of Gang Saw.
Consolidated Stone Company, Bedford, Indiana



Installation of Six Bedford All Steel Gang Saws, Consolidated Stone Company, Bedford, Indiana

Sand Pumps

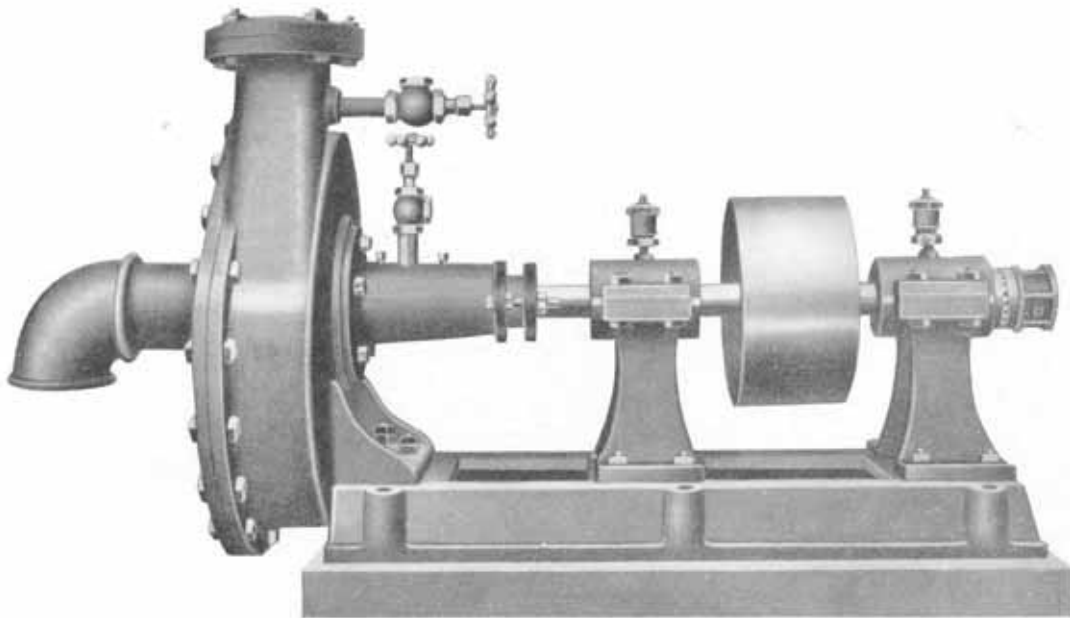

Bedford Centrifugal Sand Pump made in two sizes, namely 12" and 16"

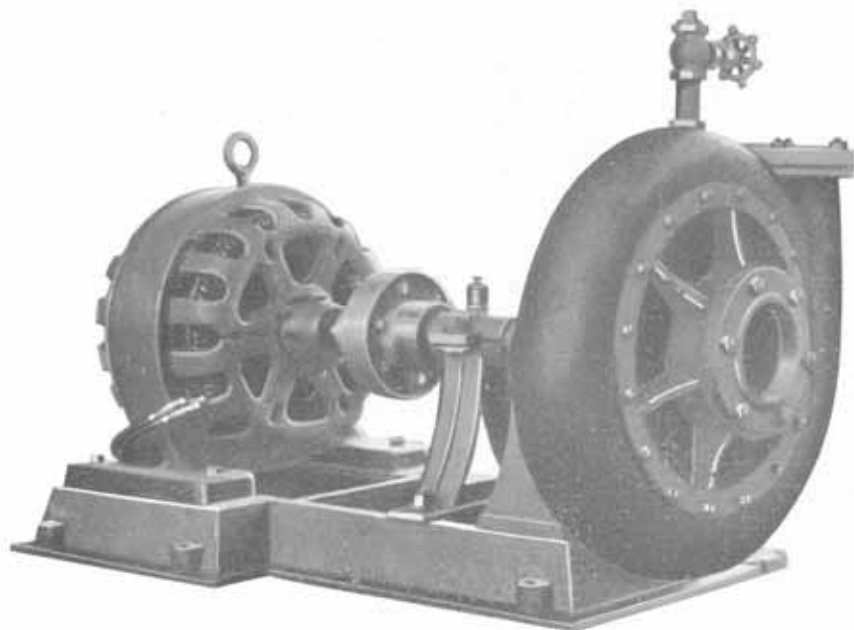

Bedford Centrifugal Sand and Water Pump made in two sizes, namely 2½" and 6" for quarry use, the 2½", 400 gallons per minute supplied with a 15 H. P. motor, the 6", 1000 gallons per minute supplied with a 30 H. P. motor

Bedford Standard Electric Traveling Cranes



WHILE Bedford Electric Traveling Cranes are built in several types to meet varying requirements, the following description of the materials and methods employed in the construction of the component parts and equipment will apply generally and serve as a guide in the selection of cranes of the types illustrated in this catalog.

Bridge Bridges are built of two steel riveted girders of the box (double web) type with curved lower flange, provided at intervals with stiffening angles, or of two riveted box girders made up of rolled beams and plates. The design depends on the load, width of span, character of service, etc. All materials used conform to the specifications adopted by the Association of American Steel Manufacturers. The girders are so proportioned that the stresses produced by the full rated load, together with the weight of the trolley, shall not exceed one-fifth of the ultimate strength of the material employed; and in top flanges a sufficiently larger safety factor is employed to insure ample rigidity under starting, stopping and running conditions specified.

Bridge Travel Bridge travel is through spur gearing of steel turned and finished with teeth cut from the solid (unless otherwise specified.) The bridge squaring shaft is of large size, supported in heavy bearings, driving truck gears at equal speeds at each end of crane. Shaft bearings are of the solid type, and have removable caps with ample provision for lubrication.

Operator's Cab The operator's cab has a framework of structural steel substantially constructed, and can be made to suit clearances. Controllers and operating devices are located and arranged for convenient manipulation by crane operator. Enclosed cab is furnished for outdoor cranes.

End Trucks End trucks support the main girders of the crane and are mounted in the truck wheels which carry the entire crane. Several designs to meet capacity of crane, span, head room, service, etc., are to be had. The bronze bearings are of a size and length to insure strength and durability. Double flanged chilled wheels of sufficient size and strength to take the maximum load if same is lifted at one end of the bridge, are furnished.

Trolley Trolleys are of heavy and substantial construction, supporting complete hoisting and trolley mechanism, and are mounted on four double flanged wheels, with machined treads. Motors, drum, brakes and principal gear shafts are all independent and easily removable. All parts accessible for convenient inspection and repair. The auxiliary hoist, when used, is mounted on end of trolley and equipped with same type brakes, gearing, etc., as the main hoist.

Hoisting Mechanism The hoisting mechanism consists of a train of spur gears. On the three- and four-motor machines all hoisting gears are enclosed in gear cases attached to and forming a part of bearings on hoisting shafts. Gears and pinions are of steel, unless otherwise specified. Main hoisting drum is on its independent shaft at top of trolley and is of liberal diameter, insuring durability on the

hoisting tackle. The surface is machined and has right and left grooves cut from the solid. The lift of hook is plumb and distributes an equal load on each girder and on each trolley wheel.

Double Hoist Brakes Two independent brakes are supplied on each hoist. The improved mechanical brake is applied to, and automatically sustains the load and assists the motor to control the lowering function. It consumes no power in hoisting. It is of the coil type on continuous shaft, and enclosed in cast iron drum. The construction is strong and durable with liberal wearing surfaces and smooth and noiseless in operation. This brake sustains the full load independently of the electric brake and absolutely prevents the load running down except as it is lowered by the power of the reversed motor. The electric brake secures positive stoppage and control, is held open by hoisting current and is instantly applied when current is interrupted.

Bearings All gear and axle bearings are capped and fitted with bronze bushings of the interchangeable type, and each gear and its shaft can be removed on lifting the caps without interfering with other parts. Axle journals have reservoir caps, and are so designed that no strain is brought to bear on cap bolts.

Motors Cranes are designed so that any standard make of crane motors, either D. C. or A. C., can be applied, clearances permitting. The motors are not a part of the crane frame but are a self-contained unit.

Wiring Crane proper is provided with first-class wiring installed throughout in accordance with the Standard Underwriters' Rules.

Safety Limit Switch Automatically prevents over-travel of block. It is self-contained, located on the trolley and operated by a positive screw. After it is thrown, stopping the hoist, the load may be lowered without resetting the switch.

Block, Hook and Sheaves Block is fitted with steel hangers and an effective tackle guard to prevent rope from getting out of grooves. The forged steel hook both swings and swivels, turning on steel ball bearings in a race of hardened

steel. Sheaves have large diameters with machined grooves and bronze bushings, with ample means of lubrication. The block falls are of a design which prevents the twisting of rope.

Hoisting Rope Flexible crane quality, special steel hoisting rope is used, unless otherwise specified.

Shafting Steel of best grade only.

Material All structural material conforms to Manufacturers' Standard specifications. Castings are free from injurious defects, made entirely from analysis; and where excessive strain is brought to bear, semi-steel castings are used. Babbitt and brasses are of strictly first grade.

General Cranes are constructed in a high grade manner throughout and neatly and serviceably painted with two coats of graphite or lead paint, bright parts being slushed.

Three-Motor Electric Traveling Crane

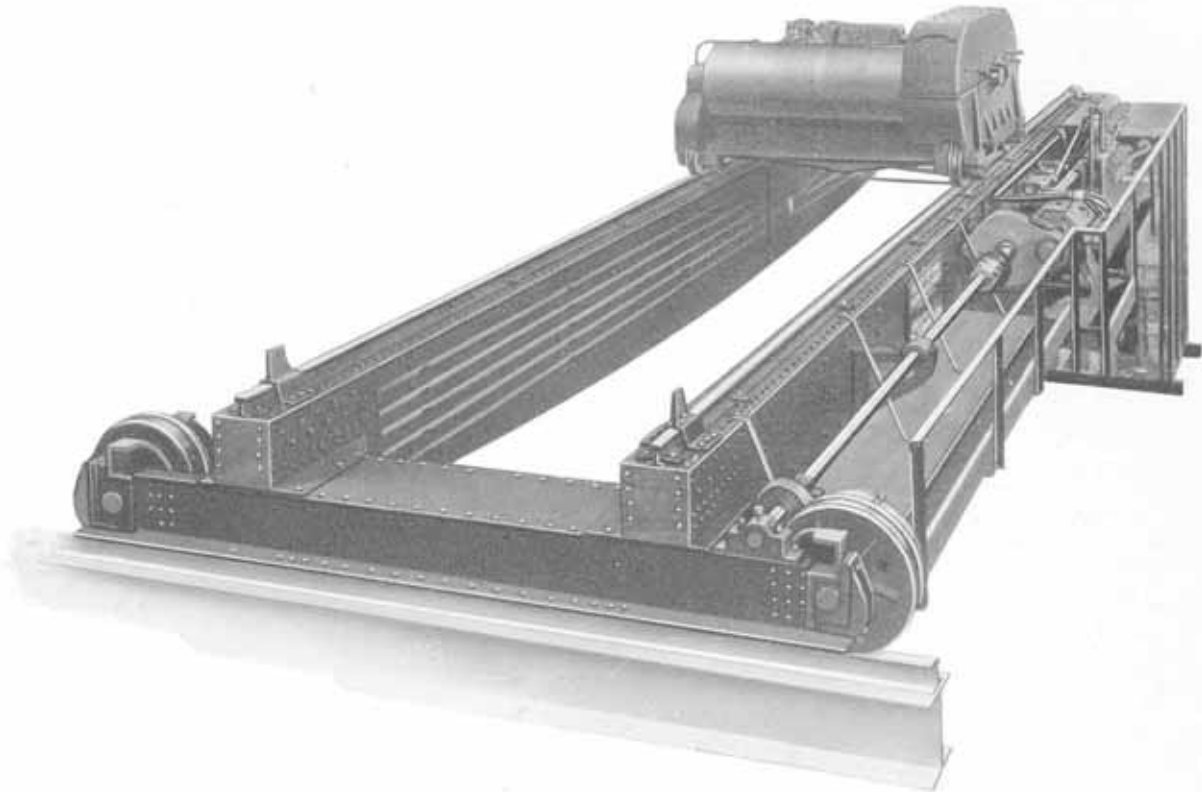

Three-Motor Bedford Electric Traveling Crane built for the Eastern Steel Co., Pottsville, Pa.

Built in sizes from 1- to 100-ton capacity for light, for medium and heavy duty. Small cranes of short span have standard I beam, while the larger and longer cranes have box type built-up girders. Cranes have structural end trucks with either M. C. B. or fixed-axle type bearings for truck wheels. Bridge wheels are of chilled cast iron, or cast steel. Foot walk provided full length of girder on squaring shaft side has toe guards and hand rail.

Standard Two-Motor Electric Crane Trolleys

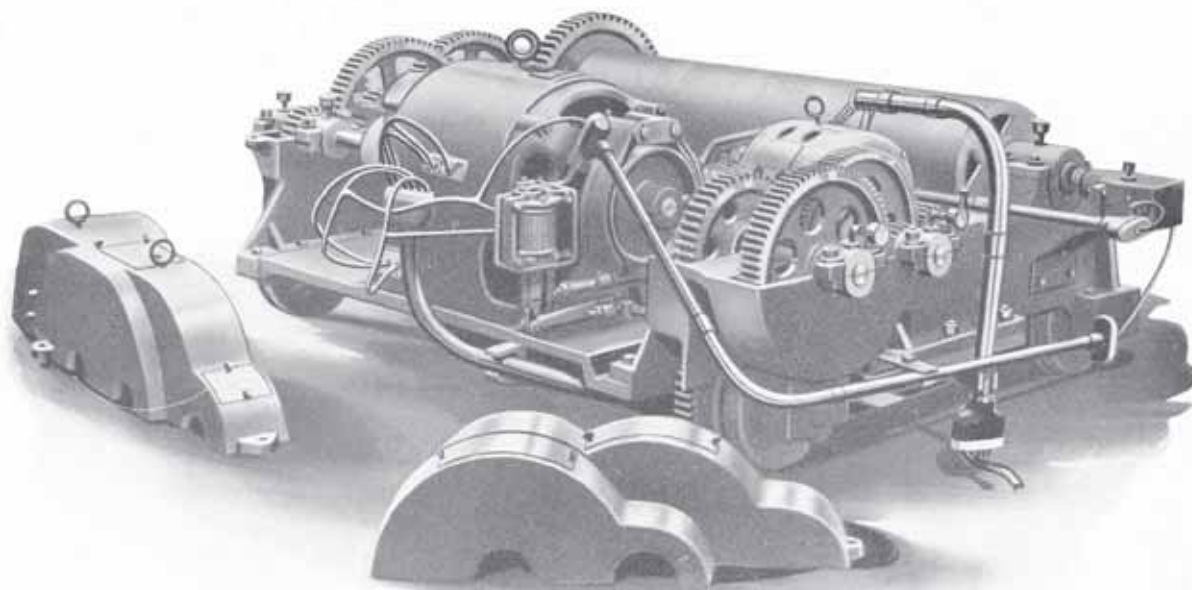

Standard five and seven and one-half ton, two-motor electric crane trolley with gear covers removed showing gears located in oil cases in the housings. Covers may be readily removed for gear inspection.

Three-Motor Electric Crane Trolley

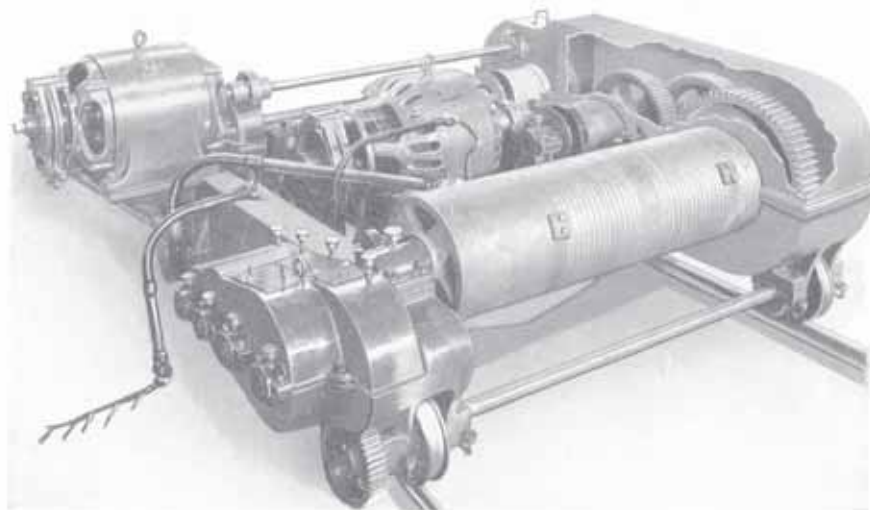

Our Standard Trolley with Auxiliary Hoist

Illustration shows the gear cover cut away exposing the gears, which run in oil cases in the housing. Covers easily removed in case of repairs.

Made in all sizes and capacities.

Traveling Cranes

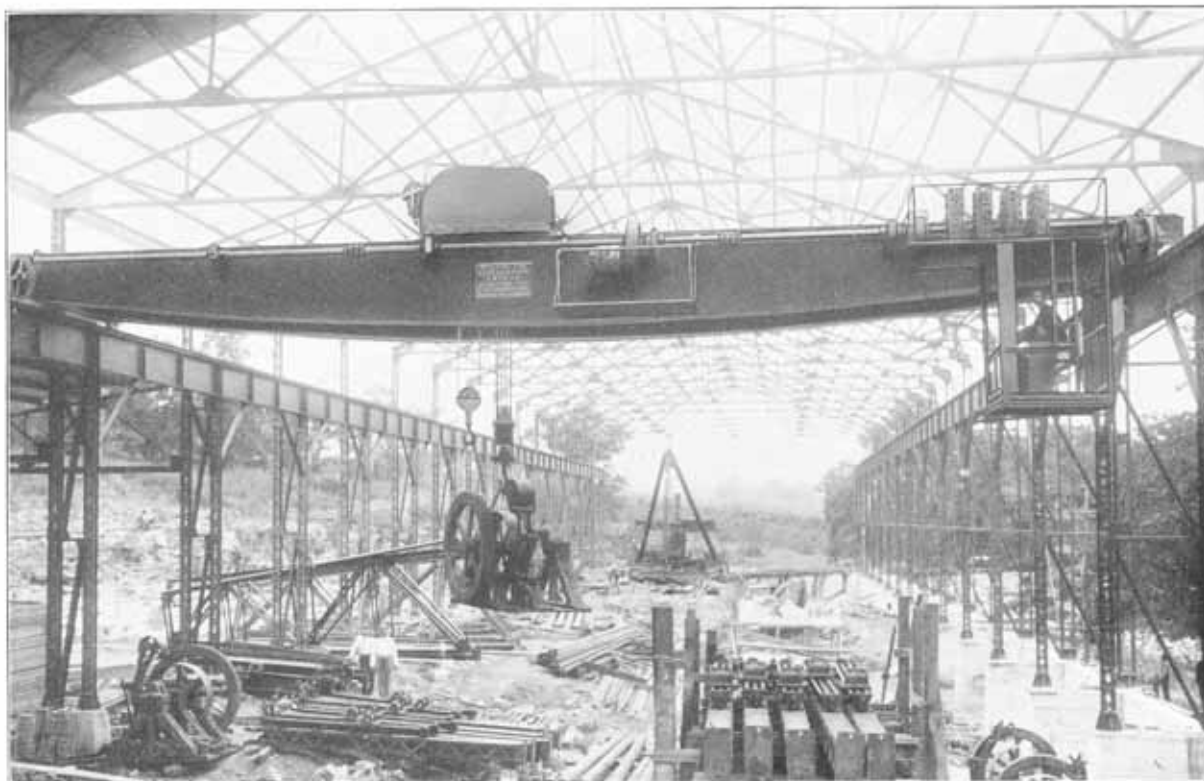

Furst-Kerber Cut Stone Company, Bedford, Indiana, using a twenty-five-ton four-motor Bedford Electric Traveling Crane



Consolidated Stone Company, Bedford, Indiana, showing 3-7½-ton 70' 0" span; 2-30-ton 70' 0" span three- and four-motor Cranes



Tedeschi & Tedeschi, Long Island City, New York. 20-ton 39' span three-motor Electric Crane



James Gillies & Sons Co., Long Island City, N. Y. 15-ton 52' 0" span three-motor Electric Crane

Bedford Electric Two-Motor Cranes

WHILE the three-motor type cranes are most commonly used throughout the industrial plants, the BEDFORD electric two-motor crane is recognized as being the best adapted for cut stone plants throughout the Bedford and Bloomington districts.

The machines are made of several types, as shown by the following cuts, capacities ranging from five to thirty tons and any span. It is possible to get all motions that can be obtained by a three-motor crane and the movements are considerable faster. The hoisting mechanism is provided with two speeds, slow speed for full loads and fast speed for light loads. The load is lowered by aid of a powerful foot brake entirely independent of the reversing motor, which is quite a saving in the power consumption and allows the load to be lowered fast or slow as desired. All structural material conforms to the Manufacturers Standard Specifications, castings are free from injurious defects, made entirely from analysis and where excess strain is brought to bear cast steel castings are used. Babbitt and brasses are strictly first grade.

Cranes are constructed in a high grade manner, neatly and serviceably painted with two coats of graphite or lead paint, bright parts being slushed.

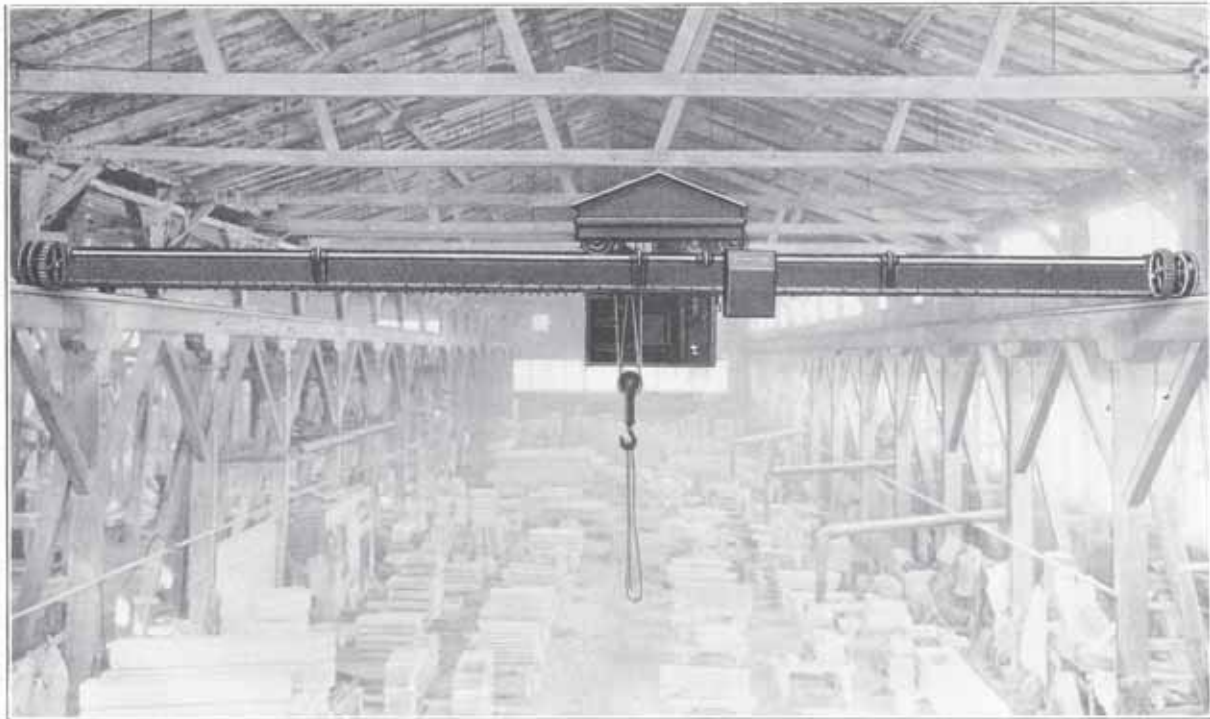

Shea and Donnely Company, Bedford Indiana, using a seven one-half-ton two-motor Bedford Electric Traveling Crane



Shea & Donnelly Company, Bedford, Indiana, using a thirty-ton two-motor 70' 0" Span Bedford Electric Traveling Crane

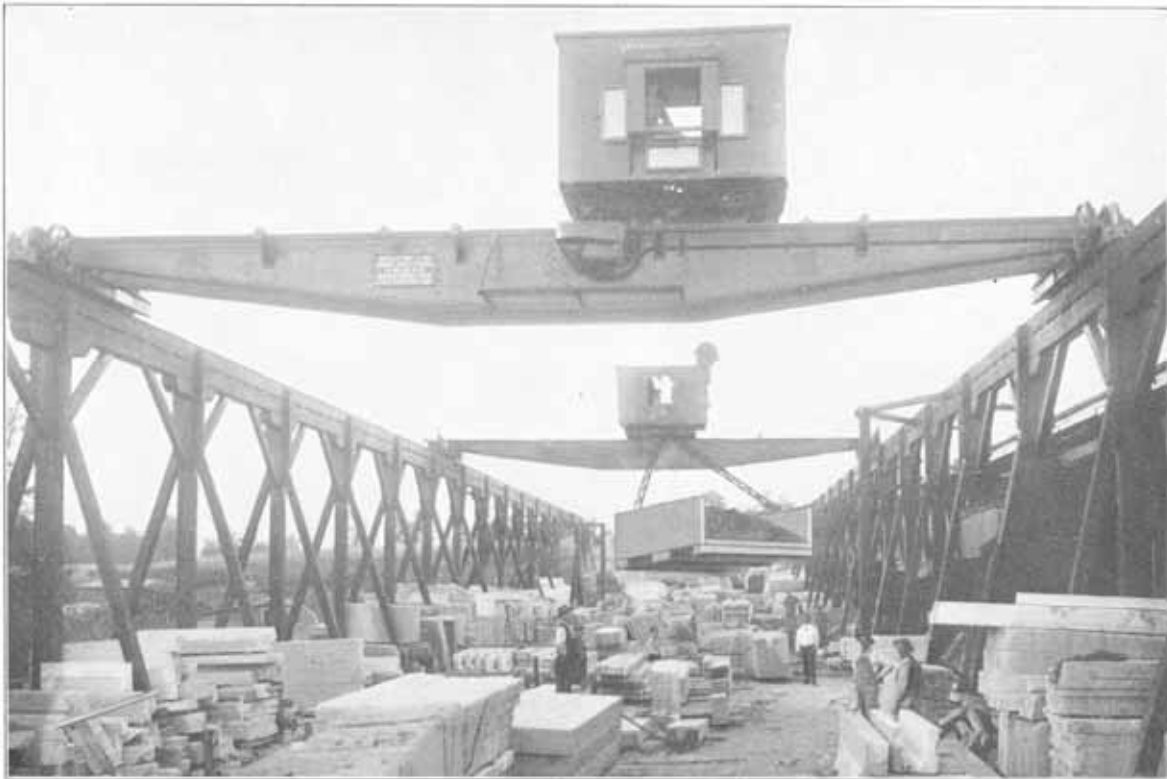

Wm. McMillan & Son, Bedford, Indiana, using two twenty-five ton two-motor Bedford Electric Traveling Cranes

Bedford Service Jib Cranes

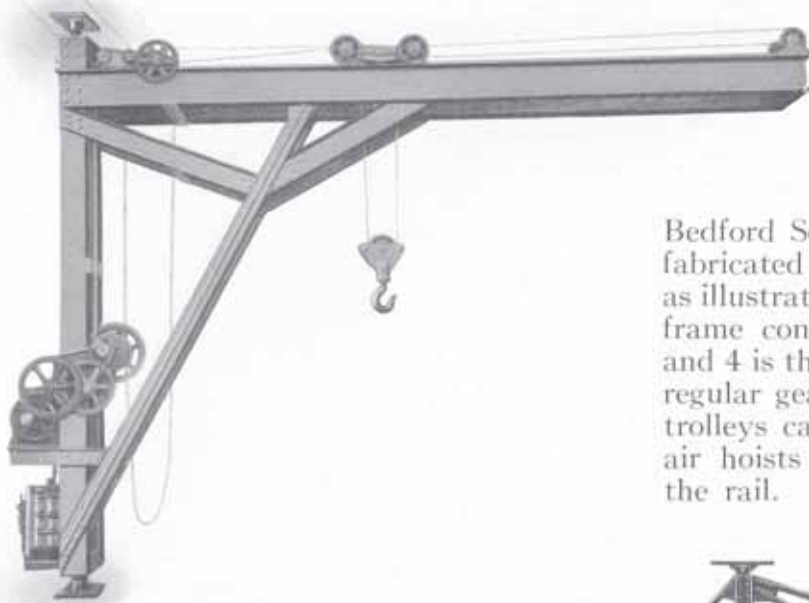

A three-ton Pillar Crane built for the United States Navy Department, at Norfolk, Virginia

Bedford Service Jib Cranes are fabricated in the standard forms as illustrated on this page. The frame construction on types 2 and 4 is the same as that on the regular geared jib cranes. The trolleys carry chain blocks and air hoists and move freely on the rail.



Type 4—Top and Backbraced Jib Crane
2 to 10-ton capacity

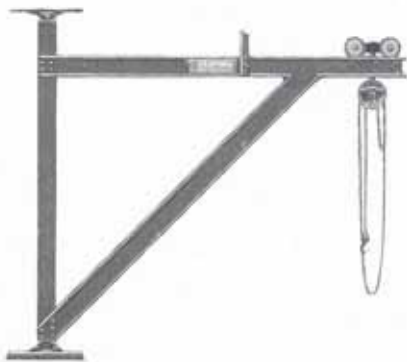

Type 2—Underbraced Jib Crane
 $\frac{1}{2}$ to 2-ton capacity



Type 1—Wall Bracket Jib Crane
 $\frac{1}{2}$ to 2-ton capacity

Jib Cranes Nos. 2 and 4 also can have electric hoists mounted on mast instead of the chain blocks, and trolley travel can be operated by hand chains.



STAMP ELECTRIC HOISTS

All Types - Every Service

AC and DC Current—Single or
Variable Speed Control

Any Standard Crane Motor can
be Mounted on Stamp Hoists

Complete Information and Prices
upon receipt of your specifications

Frame	Capacity pounds	Speed	Lift	Head Room Beam to Hook	Shipping Weight, Pounds	Cubic Contents	Trolley
H-3/4	500	22'	22'	25"	375	11'	Plain
H-3/4	1000	22'	22'	25"	375	14'	Plain
H-1	2000	25'	25'	31"	550	28'	Plain
H-1	4000	12'	12'	38"	675	28'	Plain or Hand Gear
H-1	5000	12'	12'	38"	725	28'	Hand Geared

Note.—Data above covers standard hoists with Trolley as indicated.

General Specifications

Two Reduction Spur Gears.
Hyatt Heavy Duty Bearings.
Large Diameter Drum.
Rope can not ride Drum
Flanges.
Alloy Steel, heat-treated
Gears.
Motor Brake.
Weston Load Brake.
All machinery in oil bath.
Total enclosure.
Reliable Limit Switch.
Steel Trolley and Hook Block.
Large Trolley Wheels, Roller
Bearings.
Few Parts—Long Life.
*Torn down without pulling a
Key.*

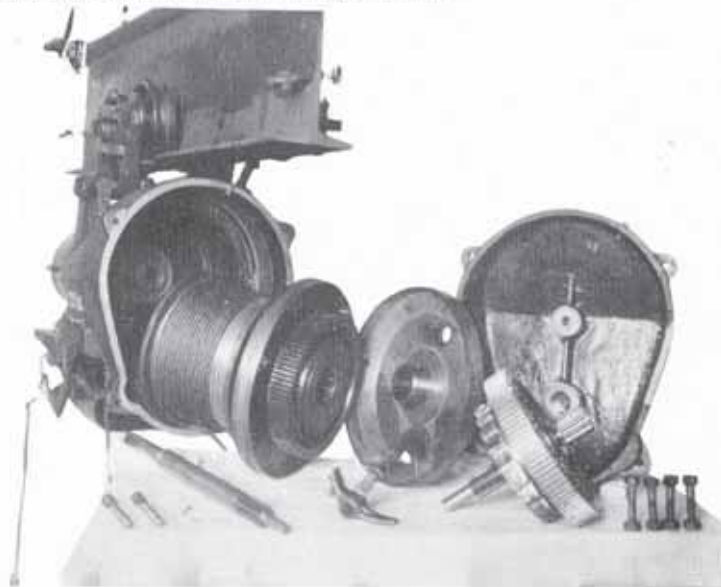

Channeling Machine

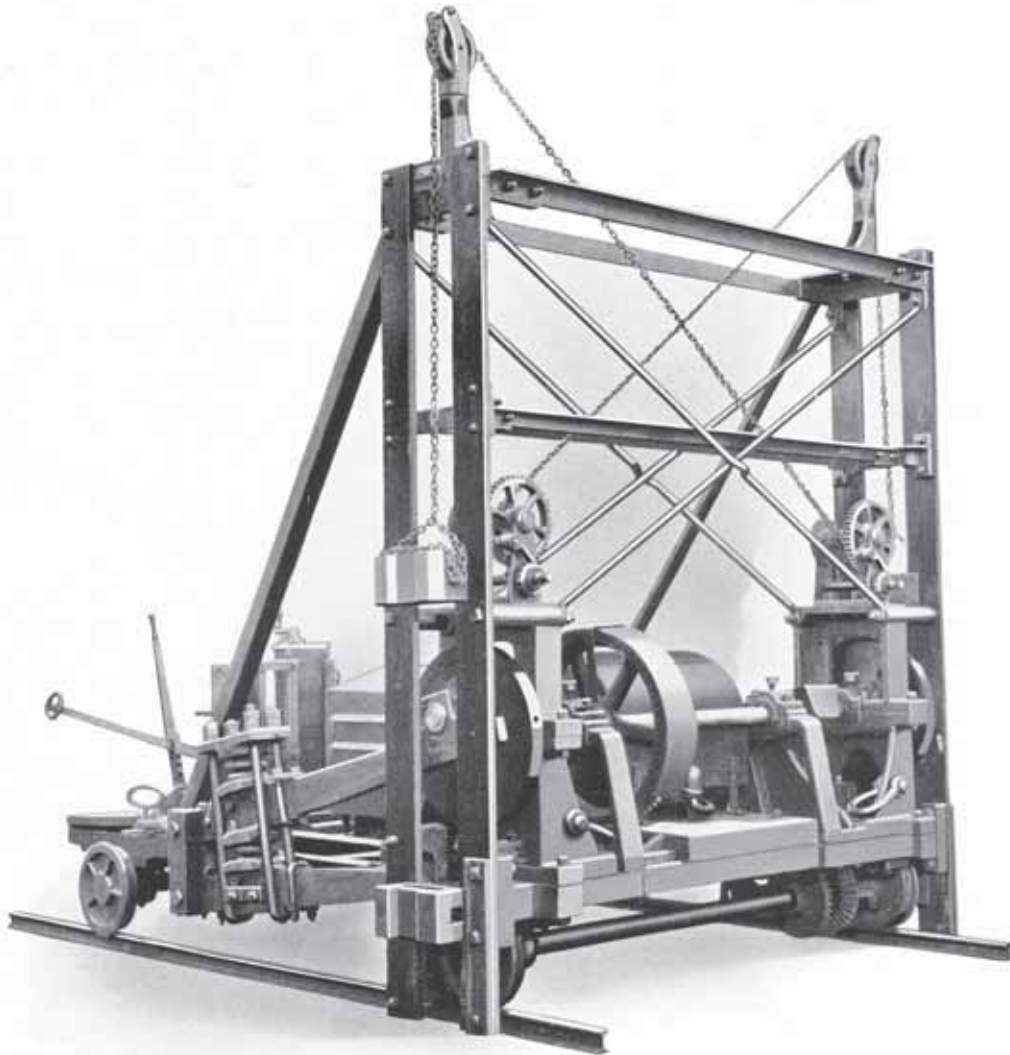

The improved Electric Wardwell Channeller, can be made in three sizes, namely 8' 4" gauge, 6' 6" gauge, 5' 2" gauge, the 8' 4" gauge being more extensively used and can be equipped with either direct or alternating current motors and are so constructed that they will cut two vertical channels without moving the track. Each side can be operated alone or both together.

The machine is rigid and of heavy construction, mounted on solid cast steel frame supported by two axles with cast steel truck wheels. Machines are built with double chair boards having double bracings. Levers furnished are made of high grade carbon steel and clamps are forged steel, machined finished. Machines are furnished with two sets of drills, long and short, with 60' 0" of track, together with the necessary tools.



Eight Bedford Electric Wardwell Channeling Machines in Operation at Dark Hollow Quarry, Bedford. Also three All Steel 30-ton capacity Steel Derricks

Thirty-Ton Bedford Steel Guy Derrick

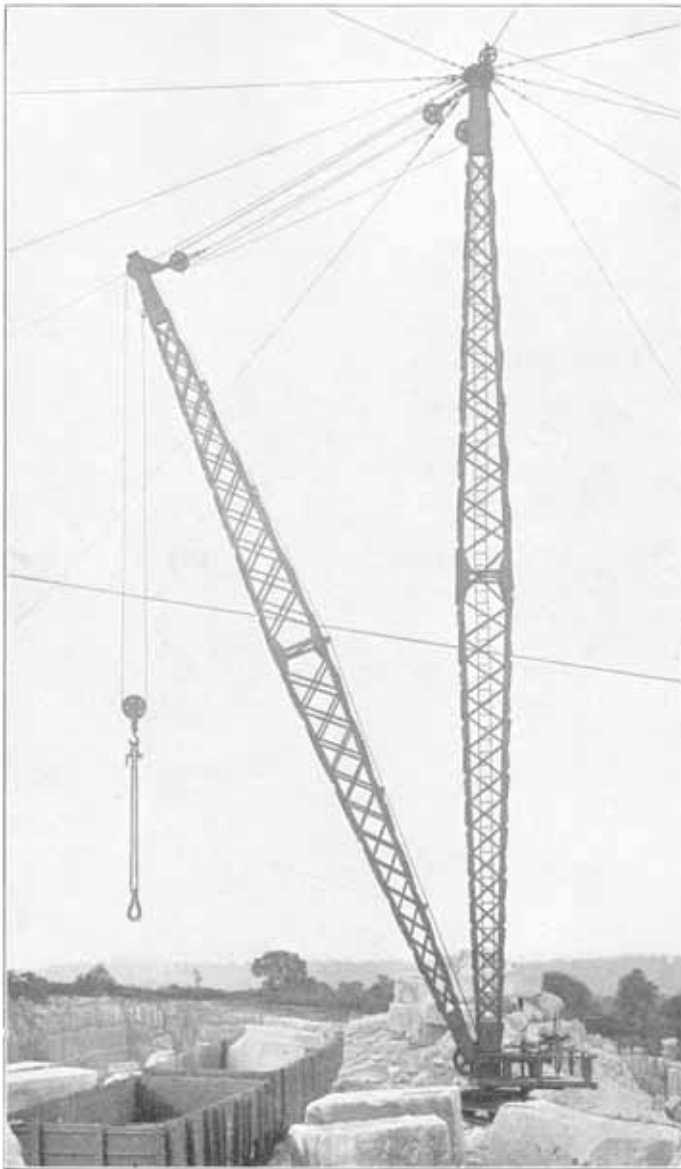

Thirty-ton Steel Guy Derrick equipped with hand-operated sluing attachment for swinging the boom.

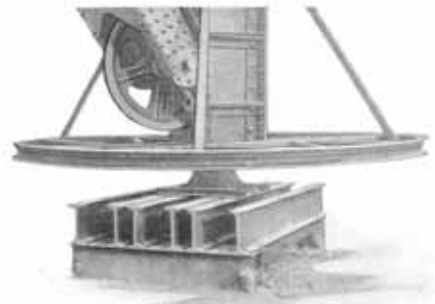

Base of derrick showing 7' 6" Bull Wheel



Derrick or Crane Dogs

Bedford Steel Guy Derrick

Illustration at left shows the Bedford Steel Guy Derrick of 40-ton capacity. The mast is 115 feet high, and the boom 100 feet in length. This derrick is in service at the works of The Ross & Republic Marble Co. of Knoxville, Tenn.

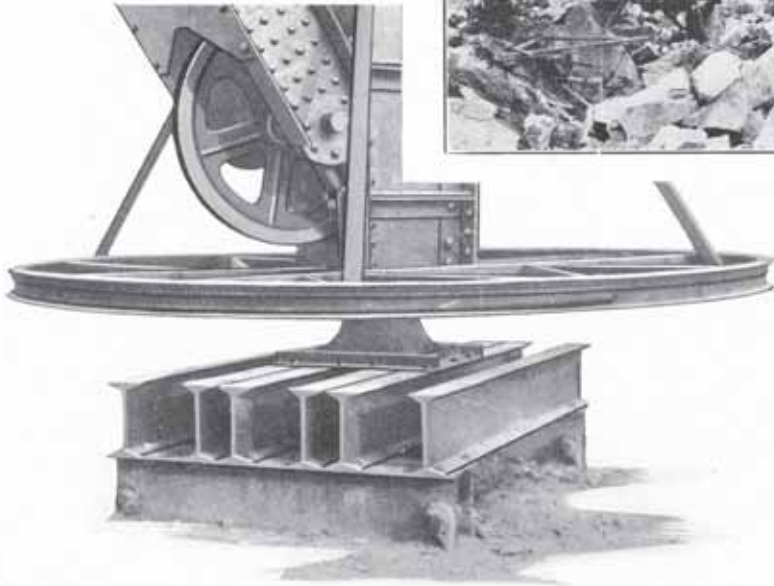

There are several other derricks of this type in the Knoxville district.

Illustration to the left shows near view of the 16-foot bull wheel used on this derrick.

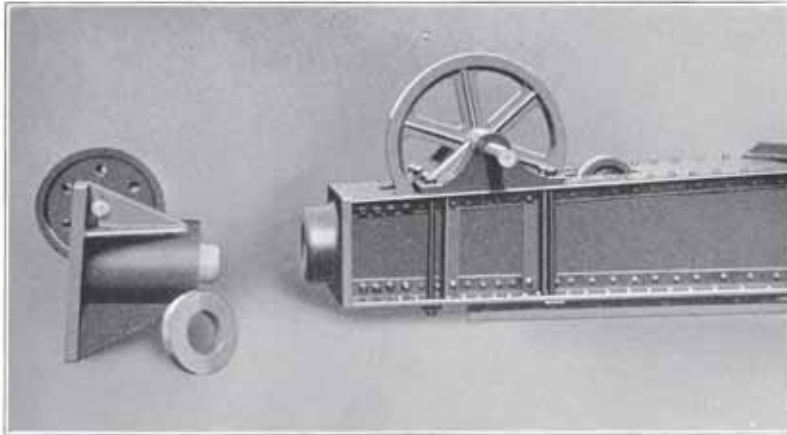

Bottom of Mast
of 40-ton Knoxville
Type Derrick

Top of Mast showing
Guy Cap, 40-ton
Knoxville Type Derrick

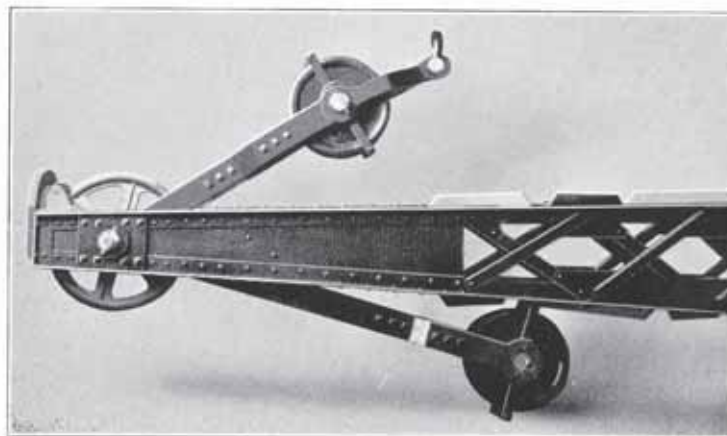
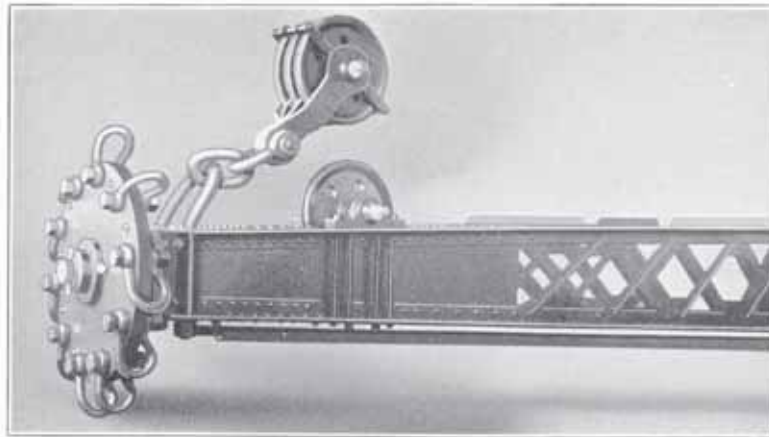

Top of Boom showing
Boom Blocks,
40-ton Knoxville
Derrick

Thirty-Ton Bedford Steel Derricks

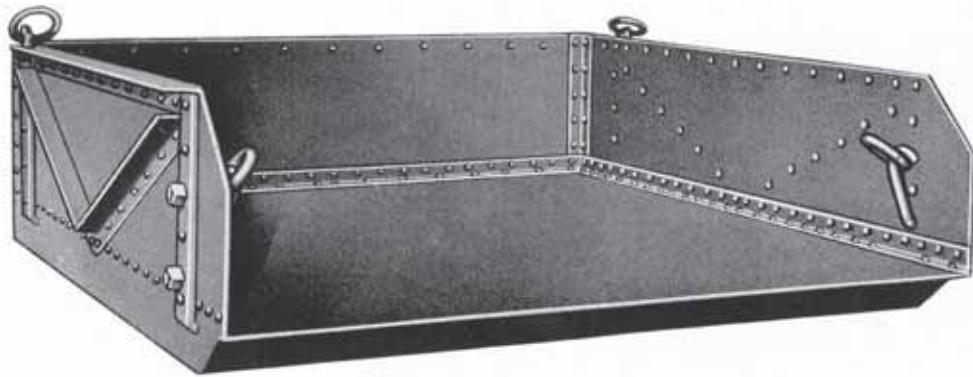
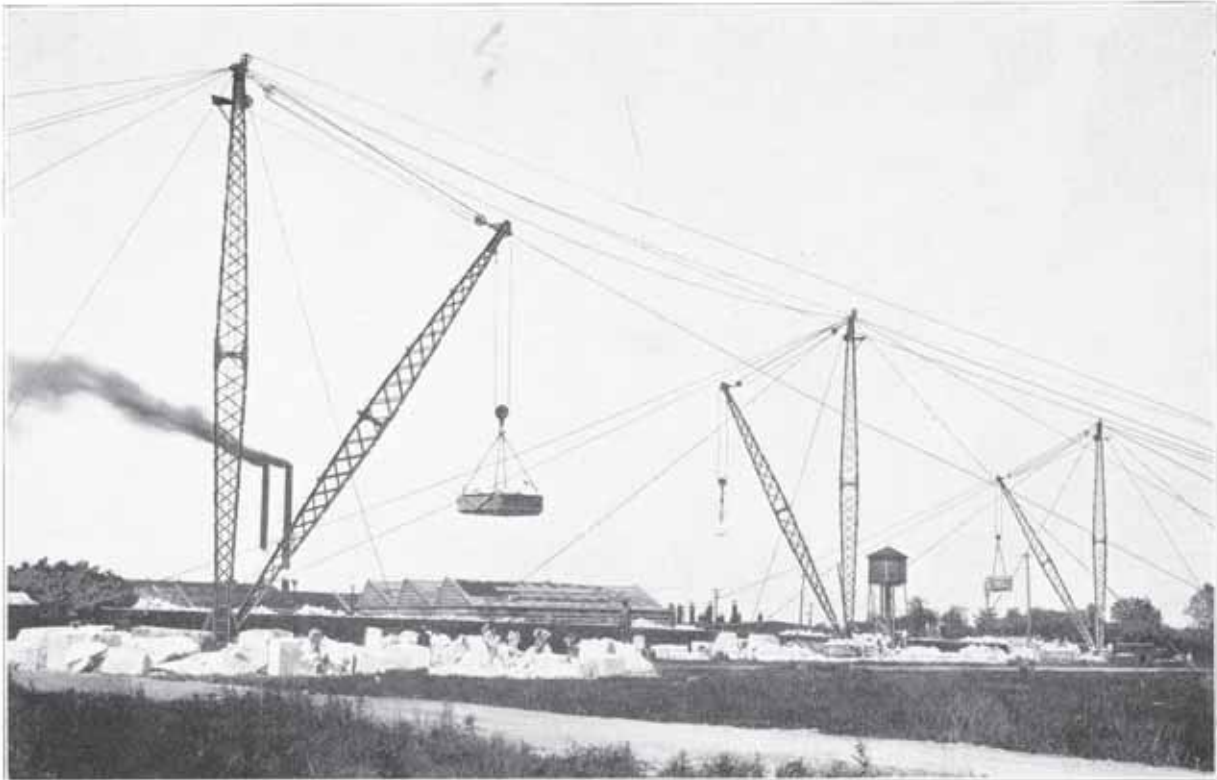

Steel Grout Boxes Made in All Sizes

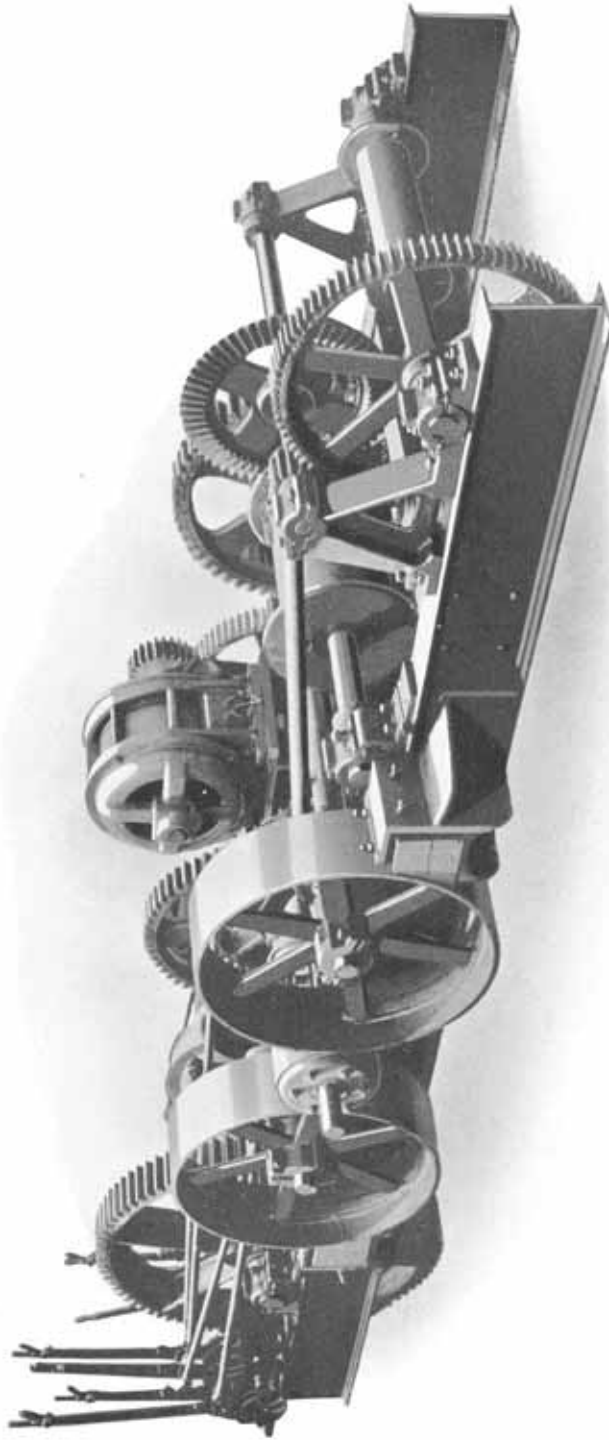

30-ton Standard Quarry Power Hoist, with Sluing Attachment
mounted on Steel Frame

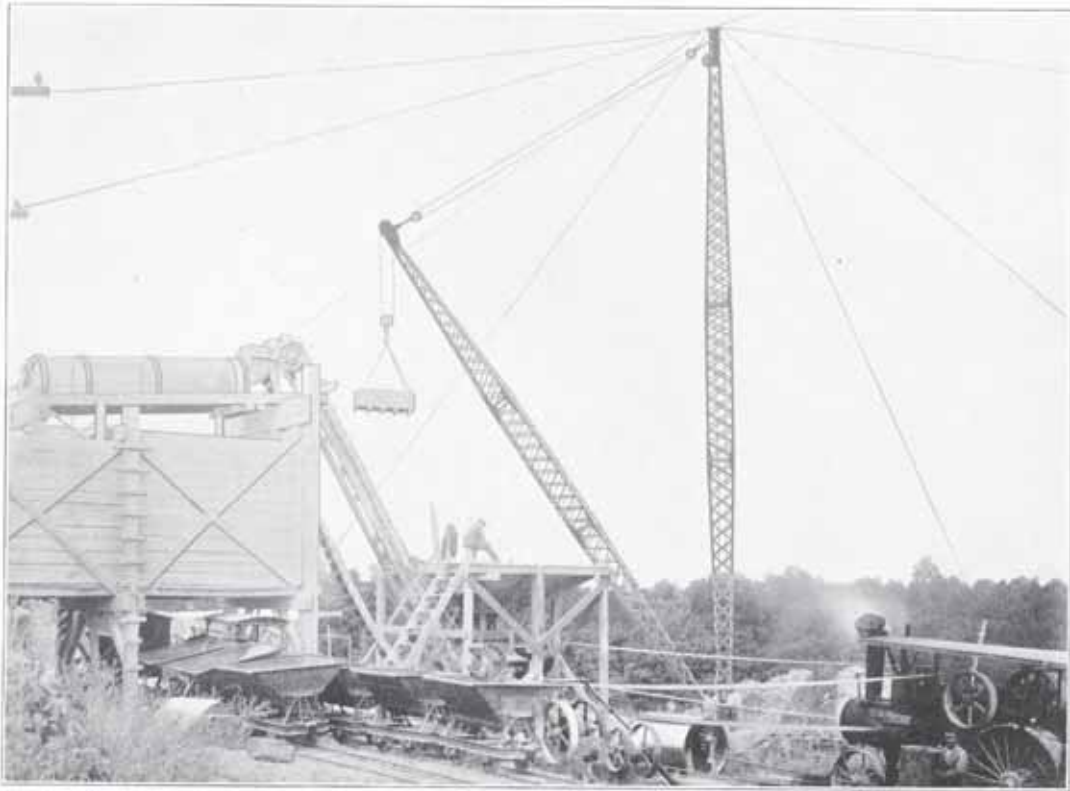

10-ton Bedford Steel Derrick, 80' 0" Boom, 90' 0" Mast

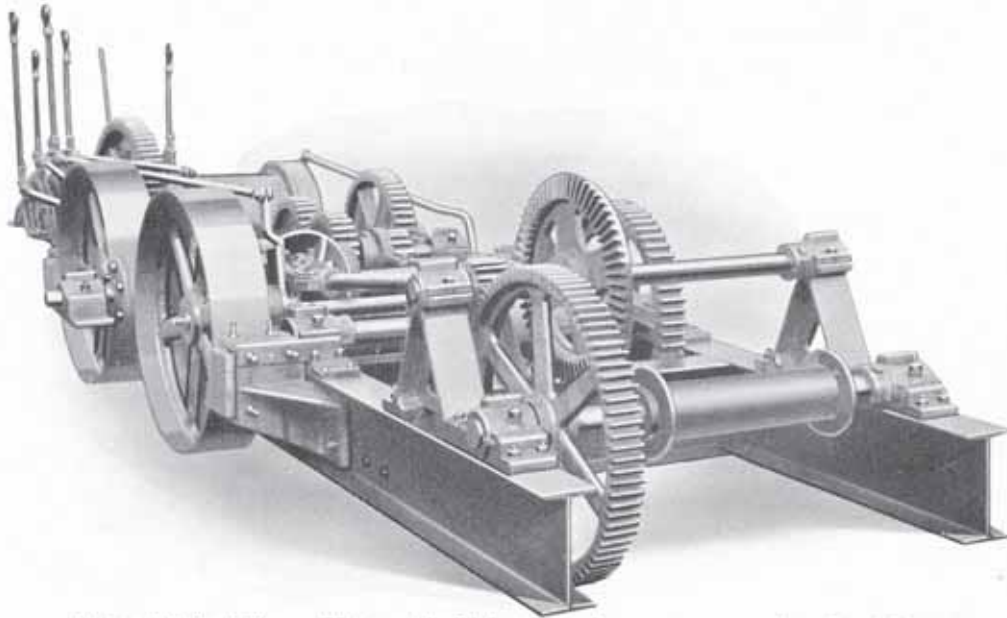

10-ton Bedford Power Hoist, with Sluing Attachment, mounted on Steel Frame



Seven 30-ton Steel Derricks, Dark Hollow Quarry, Consolidated Stone Co., Bedford, Indiana

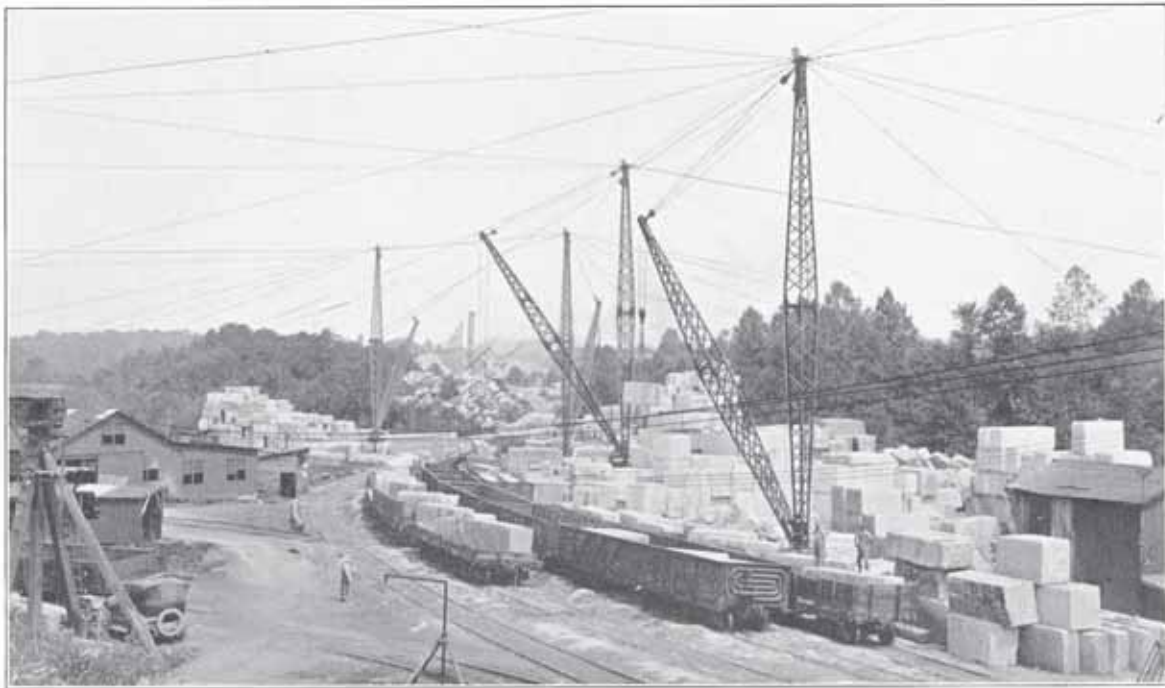

Typical Quarry Scene showing Number of Steel Derricks



Typical Quarry Scene, showing Number of Steel Derricks and Bedford Electric Channelers

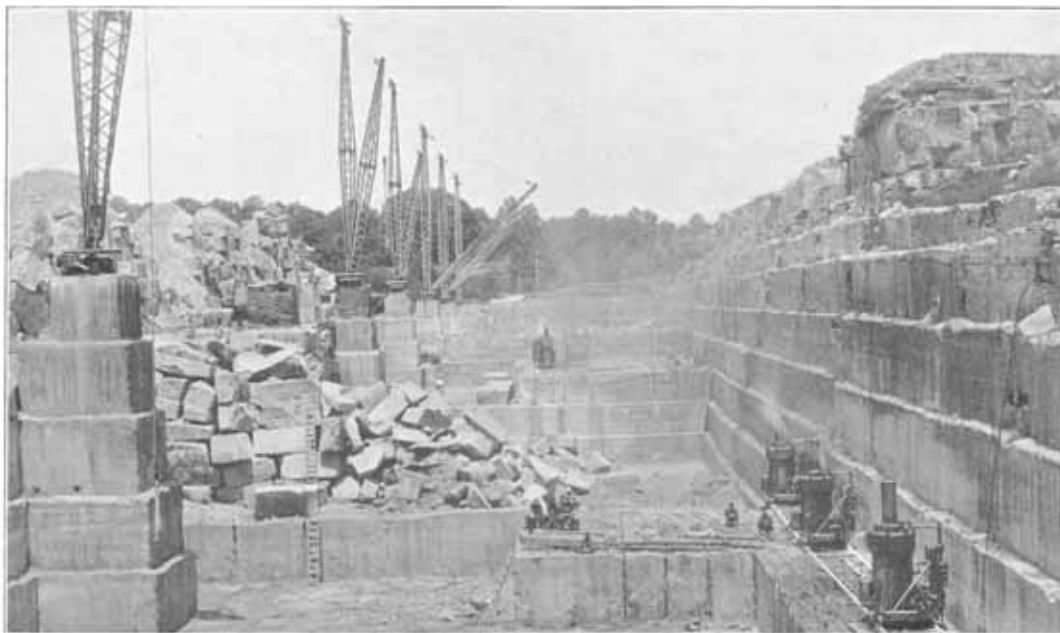

Typical Quarry Scene, showing a Number of Bedford Steel Derricks

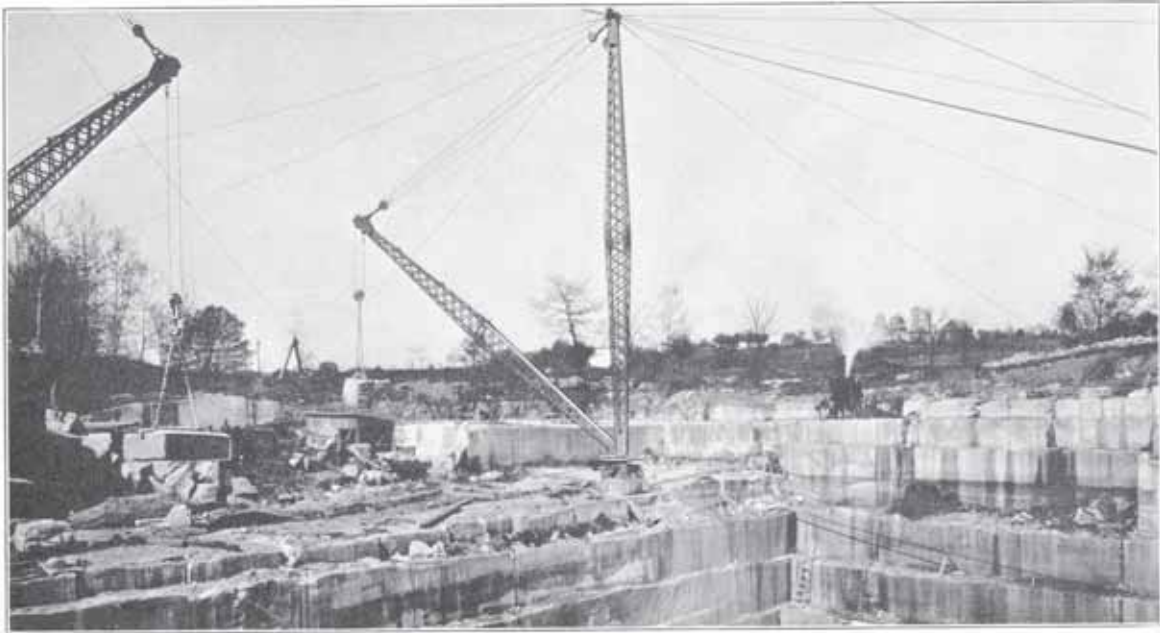

30-ton Steel Derrick, Hunter Valley Stone Co., Bloomington, Indiana



View of two Bedford Stiff-Leg Steel Derricks on construction work. These derricks are of 20-ton capacity, having 40-foot masts and 100-foot booms

Com- bined Steel Derrick and Power Hoist

View of self-contained steel derrick and power hoist combined. This derrick is motor-driven, and the hoisting, raising of the boom and revolving is all done by power from the one motor.

Illustrations below show the 10-ton capacity and the 30-ton capacity.

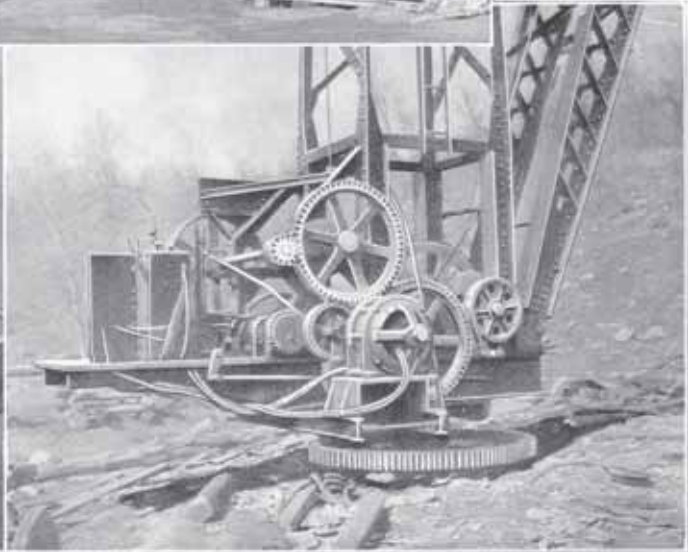
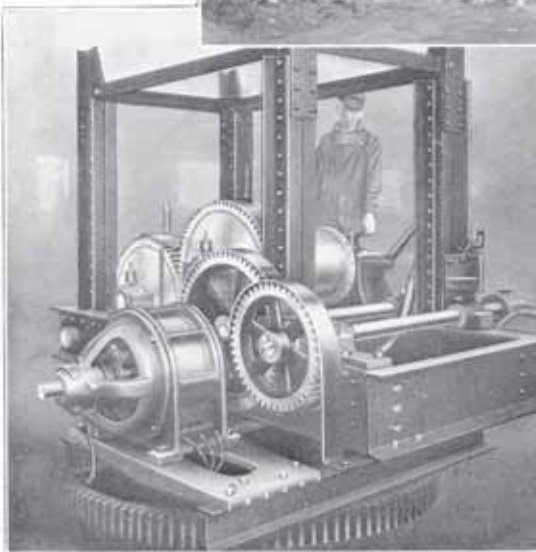
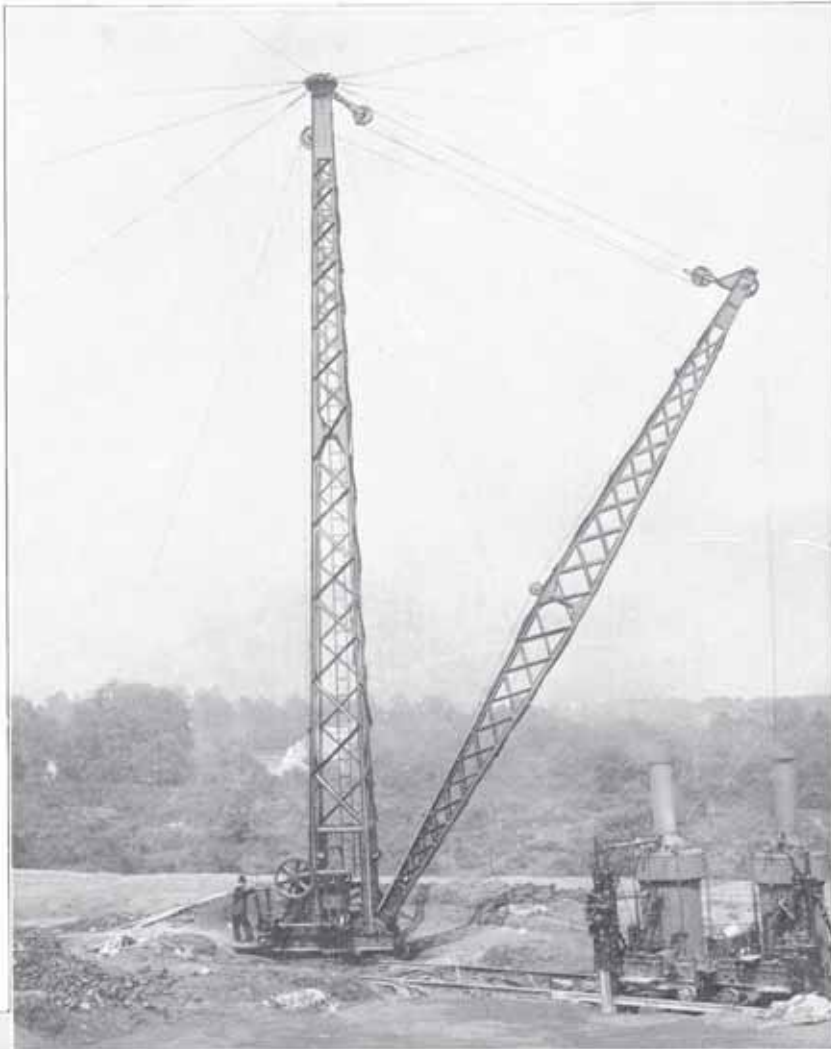



20-ton Self-Contained Complete Circle Stiff-Leg Derrick,
Rowat Cut Stone Company, Des Moines, Iowa

Thirty-Ton Capacity Stiff-Leg Derricks

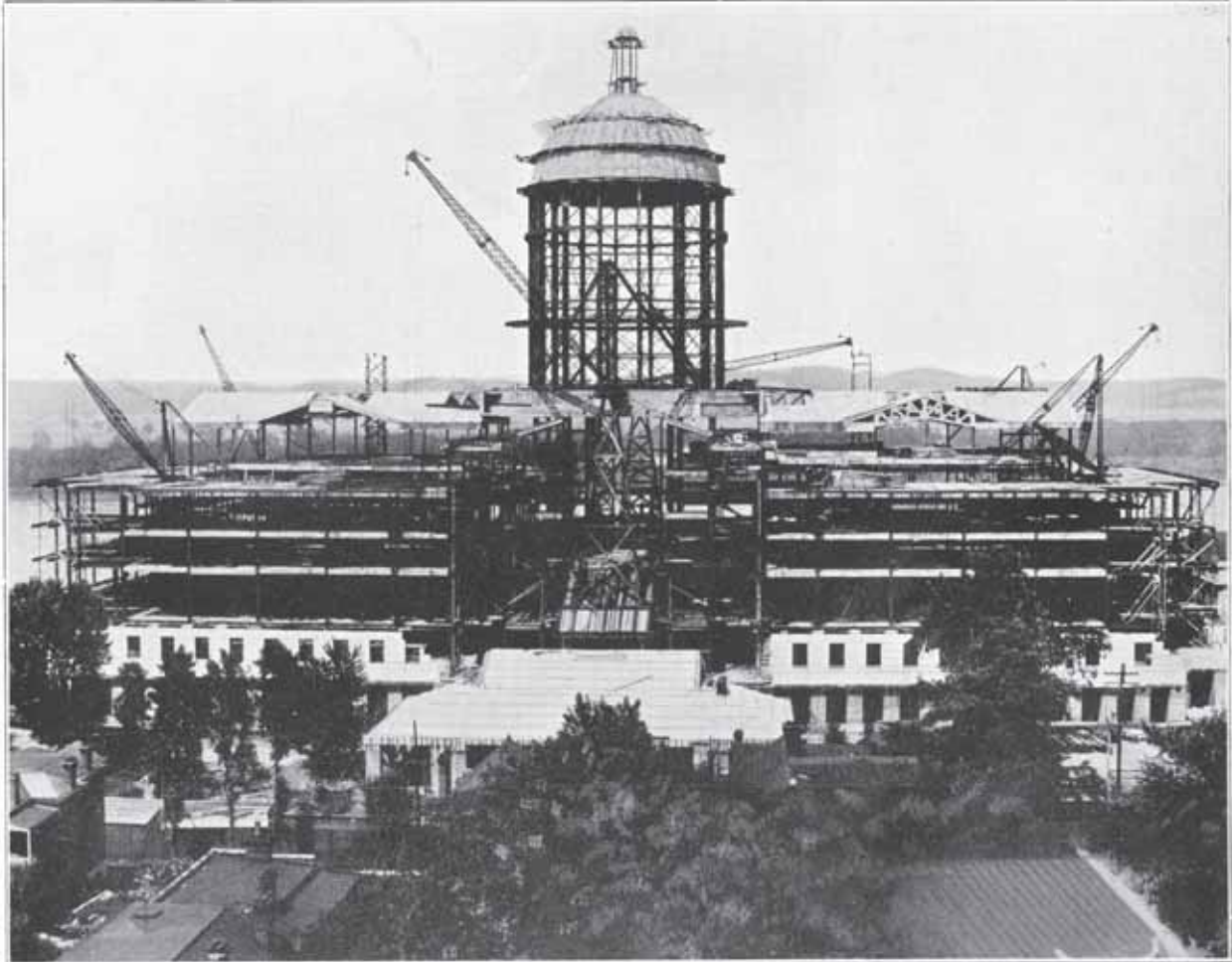

In this view of the Missouri State Capitol Building are shown a number of the Bedford 20-ton capacity steel stiff-leg derricks, used by the contractors in the erection of this beautiful structure.



Standard Mill Grout Box 4' 0" x 7' 0" x 2' 6".

Bedford Steel Boom Tower Derrick

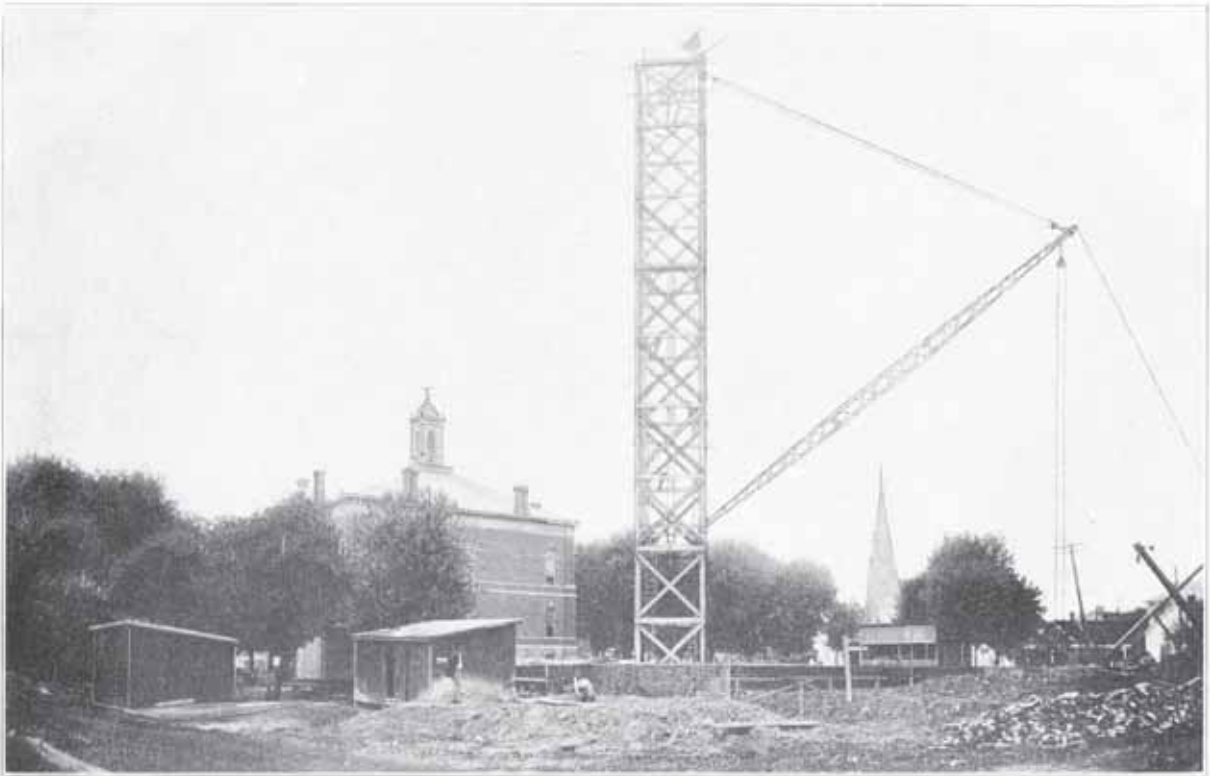

Here is shown a view of a five-ton Bedford Steel Boom Tower Derrick in place. This tower derrick has a working capacity of five tons.

Rocker Dump Car

Illustration to the right shows the Bedford Self-Acting Rocker Dump Car. These cars are V shaped and are made in sizes of 18 to 27 cubic feet capacities. Track gauge: 18 to 30 inches.

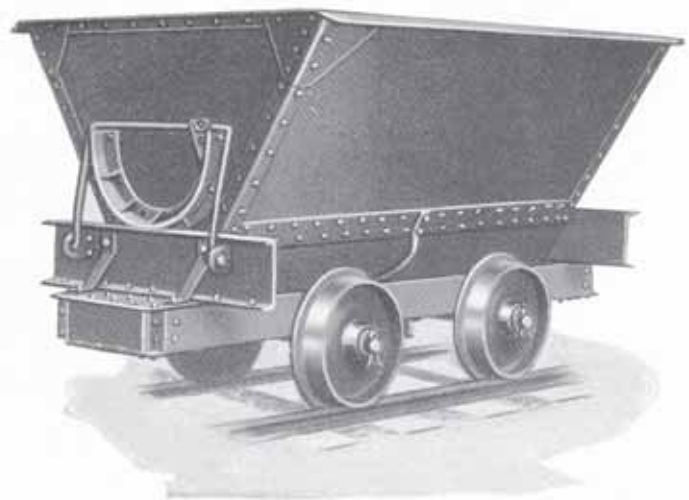

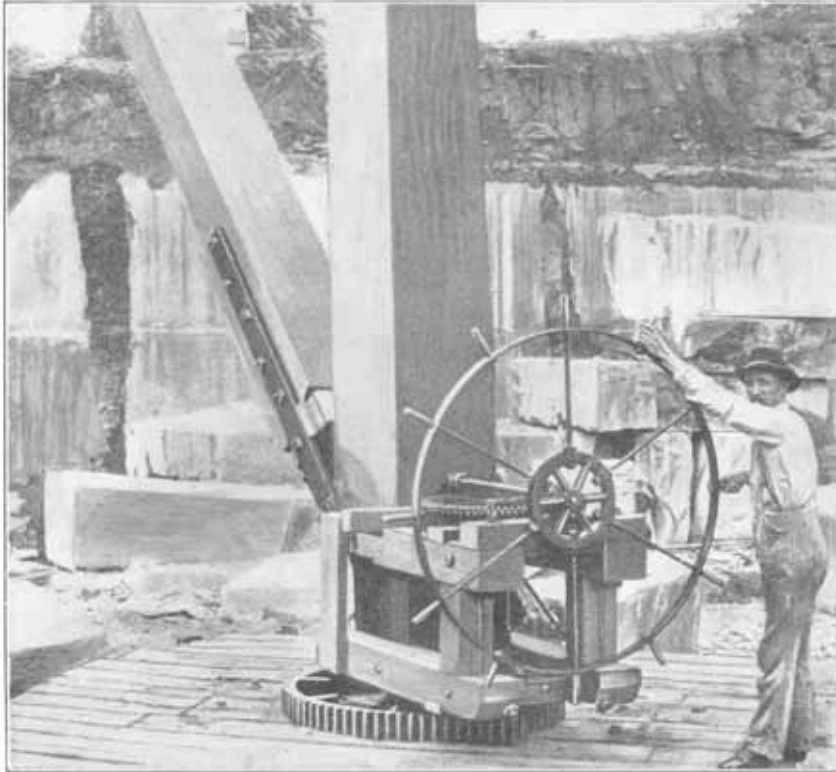

**HAND DERRICK TURNER
FOR SLUING DERRICK**

By use of this Turner one man
can operate Boom with load in
either direction.



**BEDFORD WOODEN
DERRICK**

30-ton capacity

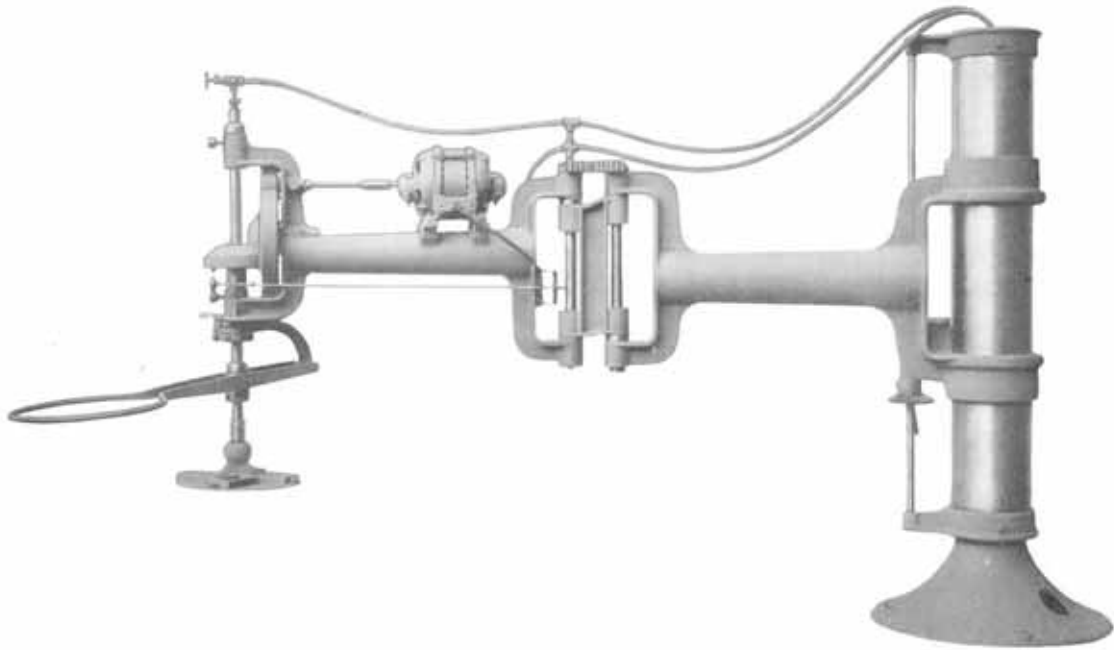

Direct Motor Connected Polishing Machine 9' 0'' Radius

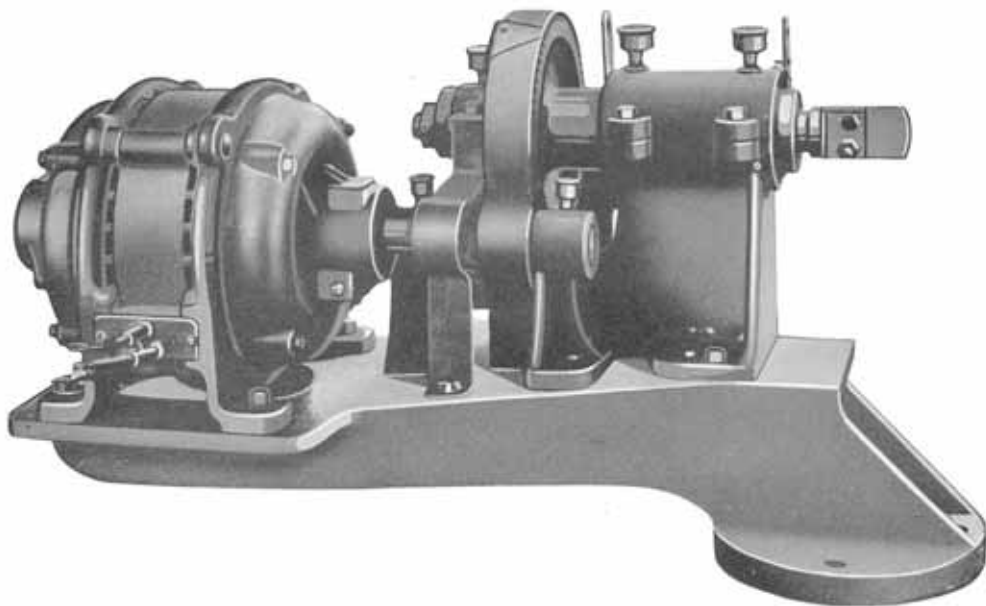

Direct Motor Driven Fluting Attachment for Lathe

